

**CITY OF BOULDER**  
**WILDLAND URBAN INTERFACE**  
**COMMUNITY WILDFIRE PROTECTION PLAN**



Prepared for:  
**City of Boulder**  
**Boulder, Colorado**  
Submitted By:  
Anchor Point  
Boulder, Colorado  
September 2007



# TABLE OF CONTENTS

---

<b>SUMMARY OF THIS DOCUMENT</b> .....	<b>1</b>
<b>THE NATIONAL FIRE PLAN</b> .....	<b>1</b>
<b>PURPOSE</b> .....	<b>2</b>
<b>GOALS AND OBJECTIVES</b> .....	<b>3</b>
<b>OTHER DESIRED OUTCOMES</b> .....	<b>3</b>
<b>COLLABORATION: COMMUNITY/AGENCY/STAKEHOLDERS</b> .....	<b>4</b>
<b>STUDY AREA OVERVIEW</b> .....	<b>5</b>
<b>WILDLAND URBAN INTERFACE (WUI) INDIVIDUAL STRUCTURE SURVEY ANALYSIS</b> .....	<b>6</b>
<b>VALUES AT RISK</b> .....	<b>10</b>
<b>LIFE SAFETY AND HOMES</b> .....	<b>10</b>
<b>COMMERCE AND INFRASTRUCTURE</b> .....	<b>10</b>
<b>RECREATION AND LIFESTYLE</b> .....	<b>11</b>
<b>HABITAT EFFECTIVENESS &amp; ENVIRONMENTAL RESOURCES</b> .....	<b>11</b>
<b>CURRENT RISK SITUATION</b> .....	<b>13</b>
<b>FIRE REGIME CONDITION CLASS</b> .....	<b>17</b>
<b>FIRE BEHAVIOR POTENTIAL</b> .....	<b>20</b>
<b>SOLUTIONS AND MITIGATIONS</b> .....	<b>27</b>
<b>ESTABLISHING AND PRIORITIZING FIRE MANAGEMENT UNITS (FMUs)</b> .....	<b>27</b>
<b>SAFETY ZONES, ADDRESSING, ACCESS, AND EVACUATION ROUTES FMU</b> .....	<b>28</b>
<b>SAFETY ZONES</b> .....	<b>28</b>
<b>ADDRESSING</b> .....	<b>29</b>
<b>PROPOSED EMERGENCY ACCESS TRAIL</b> .....	<b>30</b>
<b>EVACUATION ROUTES</b> .....	<b>32</b>
<b>PUBLIC EDUCATION FMU</b> .....	<b>35</b>
<b>LOCAL PREPAREDNESS AND FIREFIGHTING CAPABILITIES FMU</b> .....	<b>36</b>
<b>HOME MITIGATION FMU</b> .....	<b>38</b>
<b>PLAINS COMMUNITIES FMU</b> .....	<b>43</b>
<b>FUELS MODIFICATION PROJECTS FMU</b> .....	<b>45</b>
<b>INTRODUCTION</b> .....	<b>45</b>
<b>CURRENT AND PROPOSED CROSS-BOUNDARY PROJECTS</b> .....	<b>48</b>
<b>PROPOSED FUELS REDUCTION PROJECTS FOR THE CITY OF BOULDER</b> .....	<b>50</b>
<b>WATER SUPPLY FMU</b> .....	<b>52</b>
<b>GLOSSARY</b> .....	<b>55</b>

## TABLE OF FIGURES

---

FIGURE 1. Typical Area.....	5
FIGURE 2. Roof Type (2004) .....	6
FIGURE 3. City of Boulder Community Hazard Rating Map.....	7
FIGURE 4. City of Boulder Slopes .....	8
FIGURE 5. City of Boulder Elevations .....	9
FIGURE 6. USFS Fire Statistics (Boulder Ranger District).....	15
FIGURE 7. USFS Fire History Data Extent .....	16
FIGURE 8. Fire Regime/Condition Class .....	18
FIGURE 9. Flame Length, Moderate Conditions.....	21
FIGURE 10. Rate of Spread, Moderate Conditions .....	22
FIGURE 11. Crown Fire Potential, Moderate Conditions.....	23
FIGURE 12. Flame Length, Extreme Conditions.....	24
FIGURE 13. Rate of Spread, Extreme Conditions .....	25
FIGURE 14. Crown Fire Potential, Extreme Conditions .....	26
FIGURE 15. Safety Zone Guidelines.....	28
FIGURE 16.....	29
FIGURE 17.....	30
FIGURE 18. Evacuation Routes.....	32
FIGURE 19. Saddle & Ridge Top Development.....	38
FIGURE 20. Defensible Space Zones .....	39
FIGURE 21. City of Boulder Hazard Ratings by Community.....	41
FIGURE 22. Current and Proposed Projects near City of Boulder .....	49
FIGURE 23. Proposed Fuel Reduction Projects.....	50

## INDEX OF TABLES

---

TABLE 1. CWPP DEVELOPMENT TEAM .....	4
TABLE 2. STUDY AREA COMMUNITIES.....	7
TABLE 3. CONDITION CLASS DESCRIPTIONS .....	19
TABLE 4. CITY OF BOULDER HAZARD RATINGS BY COMMUNITY.....	42
TABLE 5. RECOMMENDED TREATMENT DISTANCES FOR MID-SLOPE ROADS .....	47

## SUMMARY OF THIS DOCUMENT

---

This document incorporates new and existing information relating to wildfire, and has been prepared for citizens, policy makers, and public agencies within the City of Boulder (COB) response area, Boulder, CO. Wildfire hazard data is derived from the community wildfire hazard rating analysis (WHR) and the analysis of fire behavior potential, which are extensive and/or technical in nature. As a result, detailed findings and methodologies are included in their entirety in appendices rather than the main report text. This approach is designed to make the plan more readable while establishing a reference source for those interested in the technical elements of the City of Boulder wildfire hazard and risk assessment.

The City of Boulder Community Wildfire Protection Plan (CWPP) is the result of a community-wide fire protection planning effort that includes extensive field data gathering, compilation of existing fire suppression documents, a scientific analysis of the fire behavior potential of the study area, and collaboration with various participants: homeowners, City of Boulder officials, and the Colorado State Forest Service (CSFS). This project meets the requirements of the federal Healthy Forests Restoration Act (HFRA) of 2003 for community fire planning.

### **The CWPP meets the requirements of HFRA by:**

- 1. Identifying and prioritizing fuels reduction opportunities across the landscape**  
See section *Fuels Modification FMU* on pages 45-51 of this document.
- 2. Addressing structural ignitability**  
See pages 38-44 and *Appendix B*
- 3. Collaborating with stakeholders**  
See Appendix E

## THE NATIONAL FIRE PLAN

---

In 2000, more than eight million acres burned across the United States, marking one of the most devastating wildfire seasons in American history. One high-profile incident, the Cerro Grande fire at Los Alamos, NM, destroyed more than 235 structures and threatened the Department of Energy's nuclear research facility.

Two reports addressing federal wildland fire management were initiated after the 2000 fire season. The first was a document prepared by a federal interagency group entitled "Review and Update of the 1995 Federal Wildland Fire Management Policy" (2001), which concluded among other points that the condition of America's forests had continued to deteriorate.

The second report issued by the Bureau of Land Management (BLM) and the United States Department of Agriculture Forest—Service (USFS) "Managing the Impacts of Wildfire on Communities and the Environment: A Report to the President in Response to the Wildfires of

2000”—would become known as the National Fire Plan (NFP). That report, and the ensuing congressional appropriations, ultimately required actions to:

1. Respond to severe fires
2. Reduce the impact of fire on rural communities and the environment
3. Ensure sufficient firefighting resources

Congress increased its specific appropriations to accomplish these goals. But 2002 was another severe season, with more than 1,200 homes destroyed and seven million acres burned. In response to public pressure, Congress and the Bush administration continued to obligate funds for specific actionable items, such as preparedness and suppression. That same year, the Bush administration announced the HFRA initiative, which enhanced measures to restore forest and rangeland health and reduce the risk of catastrophic wildfires. In 2003, that act was signed into law.

Through these watershed pieces of legislation, Congress continues to appropriate specific funding to address five main sub-categories: preparedness, suppression, reduction of hazardous fuels, burned-area rehabilitation, and state and local assistance to firefighters. The general concepts of the NFP blended well with the established need for community wildfire protection in the study area. The spirit of the NFP is reflected in the COB CWPP.

## PURPOSE

---

The purpose of the risk analysis, fire behavior analysis, community wildfire hazard rating (WHR) and the resulting CWPP is to provide a comprehensive, scientifically-based assessment of the wildfire hazards and risks within the COB.

The assessment estimates the risks and hazards associated with wildland fire in proximity to communities. This information, in conjunction with Values at Risk, defines “areas of concern” for the community and allows for prioritization of mitigation efforts. From these analyses, solutions and mitigation recommendations are offered that will aid homeowners, land managers and other interested parties in developing short-term and long-term fuels and fire management plans. For the purposes of this report the following definitions apply:

**Risk** is considered to be the likelihood of an ignition occurrence. This is primarily determined by the fire history of the area.

**Hazard** is the combination of the WHR ratings of the WUI communities and the analysis of fire behavior potential, as modeled from the fuels, weather and topography of the study area. Hazard attempts to quantify the severity of undesirable fire outcomes to the Values at Risk.

**Values at Risk** are the human and intrinsic values identified as important to the way of life of the study area by its inhabitants, such as life safety, property conservation, access to recreation and wildlife habitat. (See pages 9-11 for a comprehensive overview.)

## **GOALS AND OBJECTIVES**

---

Goals for this project include the following:

1. Enhance Life Safety for Residents and Responders
2. Mitigate Undesirable Fire Outcomes to Property and Infrastructure
3. Mitigate Undesirable Fire Outcomes to the Environment and Quality of Life

In order to accomplish these goals the following objectives have been identified:

1. Establish an approximate level of risk (the likelihood of a significant wildfire event for the study area)
2. Provide a scientific analysis of the fire behavior potential of the study area
3. Group Values at Risk into "communities" that represent relatively similar hazard factors
4. Identify and quantify factors that limit (mitigate) undesirable fire effects to the Values at Risk (hazard levels)
5. Recommend specific actions that will reduce hazards to the Values at Risk

## **OTHER DESIRED OUTCOMES**

---

1. Promote community awareness:

Quantification of the community's hazards and risk from wildfire will facilitate public awareness and assist in creating public action to mitigate the defined hazards.

2. Improve wildfire prevention through education:

Awareness, combined with education, will help to reduce the risk of unplanned human ignitions.

3. Facilitate and prioritize appropriate hazardous fuel reduction:

Organizing and prioritizing hazard mitigation actions into Fire Management Units (FMU) can assist stakeholders in focusing future efforts from both a social and fire management perspective.

4. Promote improved levels of response:

The identification of areas of concern will improve the accuracy of pre-planning, and facilitate the implementation of cross-boundary, multi-jurisdictional projects.

## COLLABORATION: COMMUNITY/AGENCY/STAKEHOLDERS

---

Representatives involved in the development of the City of Boulder CWPP are included in the following table. Their names, organization, and roles and responsibilities are indicated in Table 1. For more information on the collaborative process that led to the development of this CWPP, see **Appendix E, City of Boulder CWPP Collaborative Effort**.

**TABLE 1. CWPP Development Team**

Name	Organization	Roles / Responsibilities
Greg Toll, Wildland Fire Division Chief Dave Zader, Wildland Fire Management Officer	City of Boulder	Local information and expertise, including community risk and value assessment, development of community protection priorities, and establishment of fuels treatment project areas and methods.
Alan Owen, District Forester	Colorado State Forest Service	Facilitation of planning process and approval of CWPP minimum standards.
Rodrigo Moraga, Managing Member, Fire Behavior Analyst Christopher White, CEO, Urban Interface Specialist Mark McLean, GIS Project Manager Quinn MacLeod, WUI Project Specialist	Anchor Point Group LLC Consultants	Development of the CWPP, decision-making, community risk and value assessment, development of community protection priorities, establishment of fuels treatment project areas and methods.

## STUDY AREA OVERVIEW

---

The City of Boulder is located in Boulder County, Colorado. The City Of Boulder covers an area of 24 square miles, and has approximately 93,000 residents. City lands are bordered by various other suppression agencies including the Rocky Mountain Fire Protection District, Boulder Rural Fire Protection District, Lefthand Fire Protection District, Four Mile Fire Protection District, Boulder Mountain Fire Protection District, Sunshine Fire Protection District, Sugarloaf Fire Protection District, Hygiene Fire Protection District, Mountain View Fire Protection District, Coal Creek Fire Protection District, Indian Peaks Fire Protection District, Nederland Fire Department, Louisville Fire Department, and the Boulder Ranger District of the USFS.

**FIGURE 1. Typical Area**



For the purposes of this report, communities have been assessed for the hazards and risks that occur inside the department boundaries. GIS work for this project has been extended to a project boundary beyond the district boundaries. Unless noted otherwise, rankings and descriptions of communities, as well as hazard and risk recommendations, pertain only to the portions of those areas that lie within the boundaries of the City of Boulder.

The fire department service area lies within two distinct areas, the plains and the foothills. The Plains life zone, 3,500 to 5,500 feet, is where the majority of study area population resides. It is dominated by grasslands, tall grass prairie remnants and riparian vegetation (including cattails, cottonwoods and other riparian hardwoods and shrubs) growing along water courses and in drainages. The foothills area is considered to be in the Foothill/Montane life zone (6,000'-10,000') of the eastern slope of the Northern Colorado Front Range.<sup>1</sup> The dominant vegetation is Ponderosa pine (*Pinus ponderosa*) and Douglas fir (*Pseudotsuga menziesii*). The foothills area also contains dense stands of mixed conifers primarily on north facing slopes. There are also dense riparian shrub corridors and open canopy woodlands broken by large grass meadows in this area.

**Figure 3** and **Table 2** show the communities that define the WUI study area. For the purposes of this project, the wildland urban interface areas were divided into 10 communities. Each community represents certain dominant hazards from a wildfire perspective. The overall hazard ranking of these communities is determined by considering the following variables: fuels, topography, structural flammability, availability of water for fire suppression, egress and navigational difficulties, as well as other hazards, both natural and manmade. The methodology for this assessment uses the WHR community hazard rating system developed specifically to evaluate communities within the WUI for their relative wildfire hazard.<sup>2</sup> The WHR model combines physical infrastructure such as structure density and roads, and fire behavior components like fuels and topography, with the field experience and knowledge of wildland fire experts. For more information on the WHR methodology please see **Appendix B**.

---

<sup>1</sup> Elevation limits for life zones were based on life zone ranges from: Jack Carter, *Trees and Shrubs of Colorado*, Johnson Books, Boulder, CO, 1998.

<sup>2</sup> C. White, "Community Wildfire Hazard Rating Form," in *Wildfire Hazard Mitigation and Response Plan*, Colorado State Forest Service, Ft. Collins, CO, 1986.



## Wildland Urban Interface (WUI) Individual Structure Survey Analysis

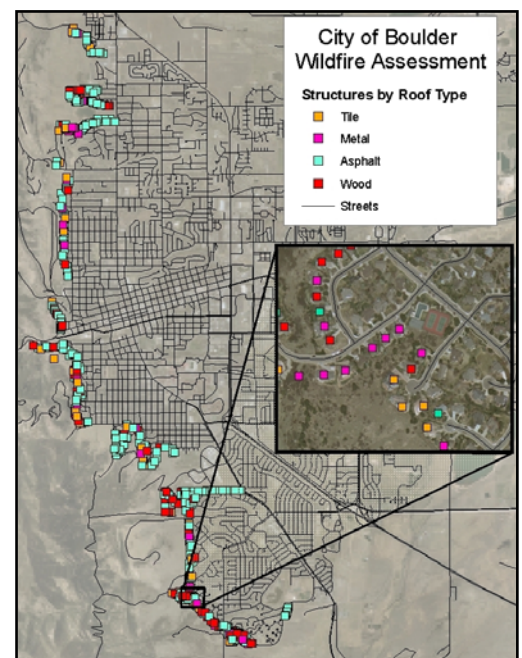
### History

In 1994 the City of Boulder enacted a roof ordinance which required the use of Class "A" or Class "B" fire rated materials when a structure was re-roofed. The impetus for the roof ordinance was a concern that under the right conditions (Chinook winds from the west) it might be possible to have embers spot on to a wood shake roof and then spread to adjacent roofs and structures.

In May of 2004 a Wildland Urban Interface (WUI) Individual Structure Survey Analysis was conducted. The findings with regards to the type of roofing composition are displayed **below and in FIGURE 2**. Of particular note, is the number of class A & B rated roofs versus the number of wood shake shingle roofs.

- Roof Type
  - 81% (520) Have (class A or B Roof) or other noncombustible roof
  - 19% (120) Have wood shake roof

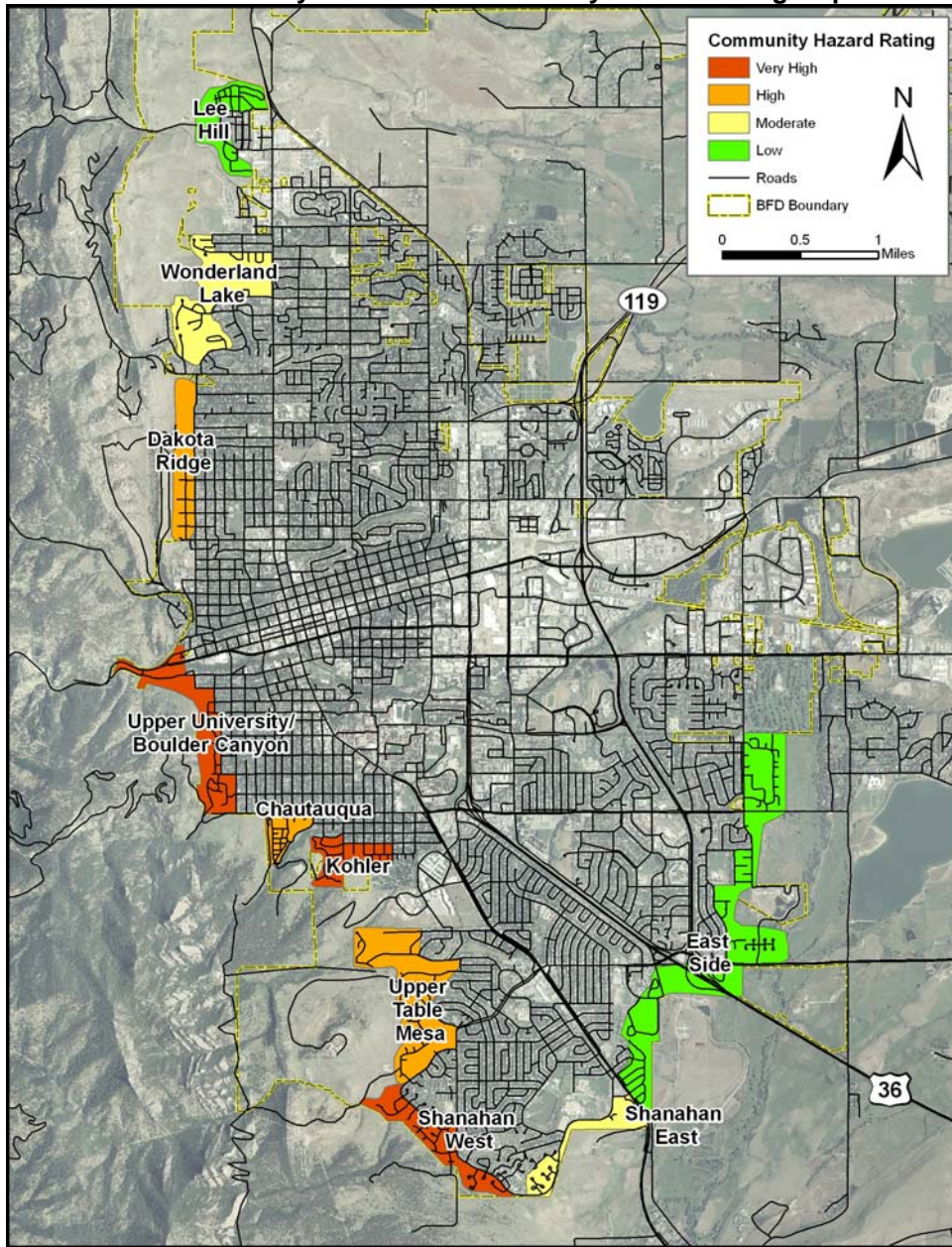
**FIGURE 2. Roof Type (2004)**



### Current Findings

While the individual home assessments from 2004 were not updated as a part of this CWPP, the CWPP field work revealed a further reduction of wood shake shingle roofs within the interface communities. Specifically, there are fewer adjacent homes with wood shake shingle roofs. This suggests yet a further reduction in the probability of structure to structure ignitions due to the composition of the roof.

**FIGURE 3. City of Boulder Community Hazard Rating Map**



**TABLE 2. Study Area Communities**

• Kohler Area	6. Dakota Ridge Area
• Upper University / Boulder Canyon Area	7. Wonderland Lake Area
• Shanahan West Area	8. Shanahan East Area
• Chautauqua	9. East Side Area
• Upper Table Mesa Area	10. Lee Hill Area

For reference to the rest of this document, **Figure 4** and **Figure 5** show the general topography of the area. These graphic representations of the landforms of the study area (elevation and slope) will be helpful in interpreting other map products in this report.

**FIGURE 4. City of Boulder Slopes**

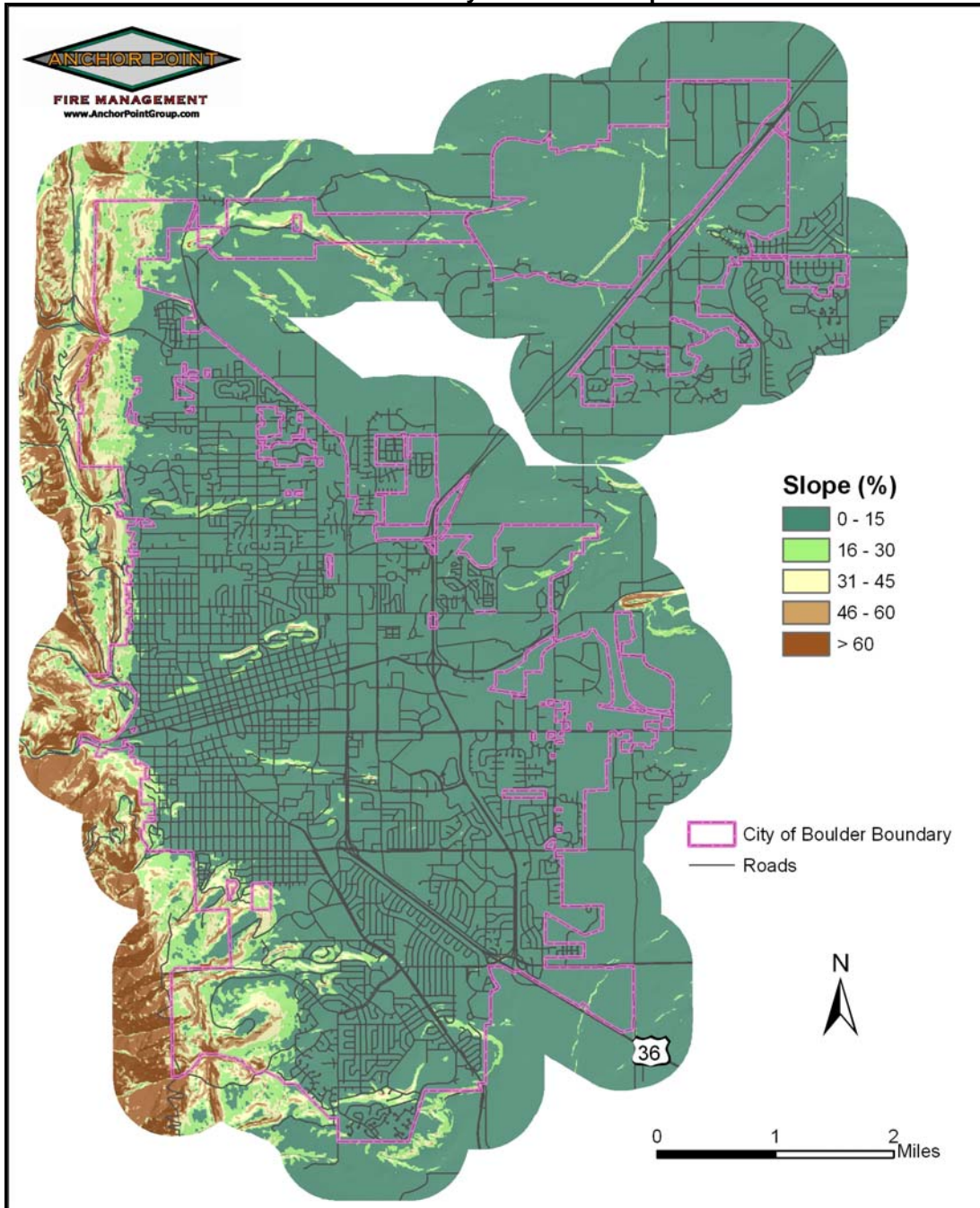
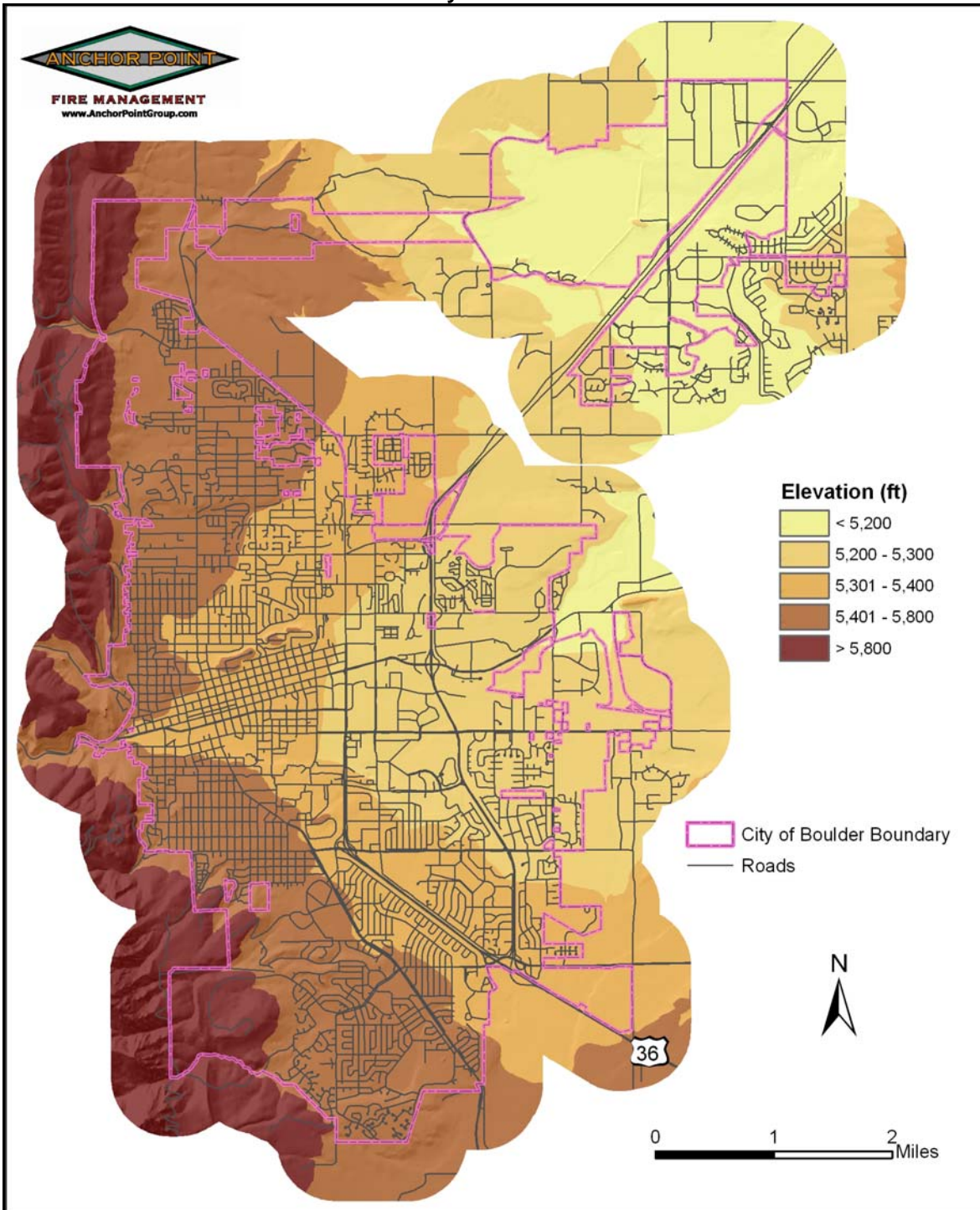


FIGURE 5. City of Boulder Elevations



## VALUES AT RISK

---

### Life Safety and Homes

There are approximately 93,000 citizens residing within the area serviced by the City of Boulder. The wildland/urban interface areas were divided into 10 communities. 9 of the 10 communities are located within close proximity to the foothills. The areas within each community represent certain dominant hazards from a wildfire perspective. Fuels, topography, structural flammability, availability of water for fire suppression, egress and access difficulties, as well as other hazards both natural and manmade, are considered in the overall hazard ranking of these communities. Of the 10 communities in the study area, the hazard assessment identified 3 that were rated very high hazard areas. Under extreme burning conditions, there is a likelihood of rapid increases in fire intensity and spread in these areas due to fast burning or flashy fuel components, and topographic features that contribute to channeling winds and promotion of extreme fire behavior. These areas may also represent a threat to life safety due to egress issues, and the likelihood of heavy smoke and heat.

The population of the City of Boulder is growing steadily – between 1990 and 2000 there was an increase of 10% – and elevated development and recreational pressures follow this increase in population.<sup>3</sup>

Boulder County has a recorded history of forest fires dating back to June 29, 1916 when 1,000 acres burned around Bear Mountain.<sup>4</sup> Boulder County experiences an average of 100 fire starts per year. Over the past 20 years the county has seen a number of major wildland fires, and until 2001, held the Colorado record for structural losses from wildland fires. This was due largely to the 1989 Black Tiger Fire, which claimed 44 homes.

### Commerce and Infrastructure

Commercial property and retail business are very limited within the Wildland-Urban Interface portions of the City of Boulder, although a small percentage of residents maintain a variety of home-based businesses. Agricultural properties and livestock-related businesses also exist in some portions of the study area.

A significant component in both the *Boulder County Comprehensive Plan* and a majority of the local municipal plans and programs is recognition of the importance of environmental factors, natural and cultural amenities, or "quality of life" issues to the health of the economy. The Boulder County economy has benefited from its legacy of careful land use decisions and its open space lands, including national and state parks, national and state forests, and city and county open space and parks.<sup>5</sup> The economy of the area is based largely on the quality of life that attracts professionals to establish residences there. Wildfire, therefore, has the potential to cause significant damage to the local economy.

---

3 <http://quickfacts.census.gov/qfd/states/08/0807850.html>. referenced 8-14-07

4 <http://www.co.boulder.co.us/sheriff/fire/firehistory.htm>. referenced 5-25-07

5 Boulder County Comprehensive Plan – Boulder County Land Use Department (<http://www.co.boulder.co.us/lu/bccp/introduction.htm>)

## **Recreation and Lifestyle**

The culture of the City of Boulder and Boulder County in general emphasizes environmental values and outdoor recreation.

Boulder citizens enjoy over 43,000 acres of city open space land in and around the city. Some of the land is in agricultural production, which helps to preserve the historic cultural landscape of Boulder County while keeping the land open for wildlife and passive recreational uses. In addition to the aesthetic pleasure of Boulder's Open Space & Mountain Parks, an extensive trail system is available for hikers and horseback riders. Bicyclists enjoy riding on designated trails. Annual visitation is estimated at 5.3 million per year.<sup>6</sup>

In 1978 the *Boulder County Comprehensive Plan* was adopted. The plan included goals and policies for preserving open space, protecting environmental resources (including both natural and cultural resources) and developing a county-wide trail system. The implementation of the open space plan has been based both on private cooperation and on the county's financial ability to acquire an interest in these lands.

By early 1998, the county parks and open space program comprised more than 52,000 acres of preserved land scattered throughout the county, along with 70 miles of trails. The majority of this land is open for public use. The remainder is under agricultural lease or conservation easements, which do not include public access. Most of the properties are well-suited to passive recreation (recreation development is limited to trails, parking areas/trailheads, picnic areas/shelters, outhouses, and simple boat docks or fishing piers where necessary).

Residents who live in the study area have a keen appreciation for their natural environment. Recreation and the natural beauty of the area – values which can be seriously damaged by wildfire – are frequently quoted as reasons local residents have chosen to live in the study area.

## **Habitat Effectiveness & Environmental Resources**

Residents are clear that the preservation of wildlife and the environment is important to the quality of life of the area. Habitat effectiveness is defined as the degree to which habitat is free of human disturbance and available for wildlife to use. Effective habitat is mostly undisturbed land area, which is buffered (at least 300 feet in essentially all situations) from regular motorized and non-motorized use of roads and trails (11 or more people or vehicle trips per week). The general rule is that habitat effectiveness should not fall below 50%; the best wildlife habitats have a much higher percentage.<sup>7</sup> Wildfire, specifically severe wildfire, can have significant adverse effects on habitat effectiveness.

The environmental character of Boulder County is due in large measure to the abrupt altitudinal variation within a 20-mile east-west gradient. The dramatic landform changes sharply define the native ecosystems and their associations of plant and animal species.

The county's environmental heritage includes non-renewable resources such as natural areas, historic/archaeological sites and natural landmarks. As irreplaceable resources, they warrant preservation from destruction or harmful alteration. Wetlands are critical environmental

---

<sup>6</sup> [http://boulder.colorado.gov/index.php?option=com\\_content&task=view&id=1167&Itemid=1085](http://boulder.colorado.gov/index.php?option=com_content&task=view&id=1167&Itemid=1085). referenced 8-14-07

<sup>7</sup> Peak to Peak Community Indicators Project 2003 Presented by Peak to Peak Healthy Communities Project ©Copyright 2003 Peak to Peak Healthy Communities Project

resources that function variously as wildlife habitat, aquifer recharge areas, and linkages in the overall county wildlife system, and aids for smog control.

The goal of the *Boulder County Comprehensive Plan* is to maintain and monitor the forests on open space land in ways that will benefit the ecosystem and the public. Activities include:

- Assessing overall forest conditions through forest inventories and surveys
- Implementing prescriptions based on the results of these inventories and surveys
- Taking action to change or increase the individual tree's health and vigor
- Reducing fire danger
- Improving or maintaining wildlife habitat
- Maintaining and preserving the aesthetic and ecological value of the forest

The City of Boulder CWPP process is in concert with these guiding comprehensive plan principles. Through public involvement, local support and a regional perspective, the fuels reduction elements described in this document can and should enhance and protect the values of the study area.

## Current Risk Situation

For the purposes of this report the following definitions apply:

**Risk** is considered to be the likelihood of an ignition occurrence. This is primarily determined by the fire history of the area.

**Hazard** is the combination of the wildfire hazard ratings of the Wildland Urban Interface (WUI) communities and fire behavior potential, as modeled from the fuels, weather and topography of the study area.

The majority of the interface areas of the city are at a high risk for WUI fires. This assessment is based on the analysis of the following factors:

1. The City of Boulder is listed in the Federal Register as a community at high risk from wildfire (<http://www.fireplan.gov/reports/351-358-en.pdf>).
2. The area is shown in the Colorado State Forest Service WUI Hazard Assessment map to be an area of high Hazard Value (an aggregate of Hazard, Risk and Values Layers).
3. The City of Boulder responded to a total of 173 wildland fire incidents in the years from 2002 through 2006. These annual totals include fires responded to by the both fire and OSMP departments.
4. No major fires (fires greater than 100 acres) have burned in the city since 2002 (the Wonderland Lake Fire), but major fires have occurred near the city recently, including the Overland Fire (2003) and a number of large (100 acres +) grass fires in the winter of 2006. It is important to note there are over 20 fire departments in Boulder County, and many mutual aid agreements are in place. The Boulder area has a large number of well-trained resources. Ignitions in this area attract a rapid, professional response and are generally extinguished quickly.
5. Fire history statistics from the Colorado State Forest Service (CSFS) and their cooperator fire departments reflect an active fire history for the years available. CSFS reports 100 fires in 1990, 104 in 1991, 126 in 1992, and 98 in 1993, for a total of 428 in Boulder County for the four-year period.
6. The USDA Forest Service fire regime and condition class evaluation of forest stands in the study area shows that historic fire regimes have been moderately altered. Please see the *Fire Regime and Condition Class* section of this report for details.
7. The surrounding federal lands report an active, but far from extreme, fire history. Fire occurrences for the Boulder Ranger District of the Arapahoe-Roosevelt National Forest (see **Figure 6**) were calculated from the USDA Forest Service Personal Computer Historical Archive for the thirty-year period from 1977-2006. These areas represent federal lands adjacent to the study area, but do not include any data from state, county, or private lands. The data have been processed and graphed using the Fire Family Plus software program and are summarized below.

**Figure 6a** shows the number of fires (red bars) and the total acres burned (blue hatched bars) in the Boulder Ranger District for each year. While the number of annual fires ranges from approximately 5 to over 30 fires per year, there is little year-to-year pattern to the variation. The single largest fire for acreage burned was the Overland Fire (2003). Of the 9,854 acres reported burned in the ranger district between 1977 and 2006, 3,869 were burned by the Overland fire.



Between 1977 and 2006 there were three other fires that burned more than 100 acres in the ranger district. The total number of acres burned was the greatest in 1988, when two large fires accounted for 3,922 acres burned. 1988 also had the highest number of fires on the Boulder Ranger District during the study period. A portion of the Black Tiger Fire also burned 1,804 acres in the Boulder Ranger District in 1989.

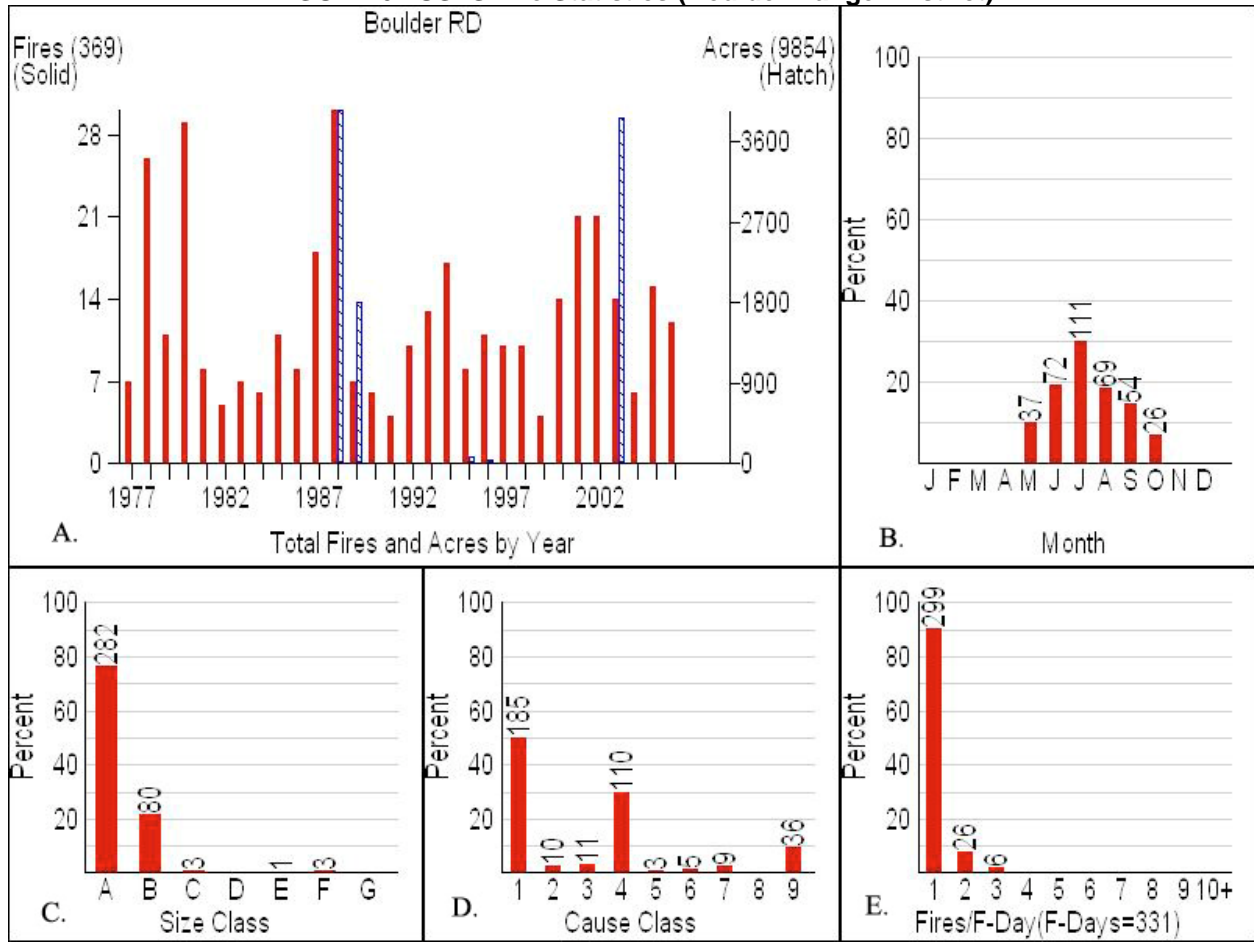
**Figure 6b** shows the percentage and number of fires between 1977 and 2006 occurring in each month of the year. July had the greatest number of fires, followed by June and August. The fewest fires occurred between the months of November and April, a fact which reflects the climate conditions for the area.

**Figure 6c** shows the size class distribution of fires. Approximately 98% of the reported fires (362 of 369) were less than 10 acres in size. These statistics reflect the widely held opinion that, throughout the western US, the vast majority of fires are controlled during initial attack.

**Figure 6d** shows the number of fires caused by each factor. As shown in this graph, the most common cause of ignitions is lightning (50%). However, the next most common cause is campfires (30%). If we remove the miscellaneous cause category, natural causes still represent the majority of ignitions (56% natural and 44% human-caused), but it should be noted that these numbers are for national forest areas which lack the concentrated development and many other risk factors present in the portions of the study area where private land is dominant.

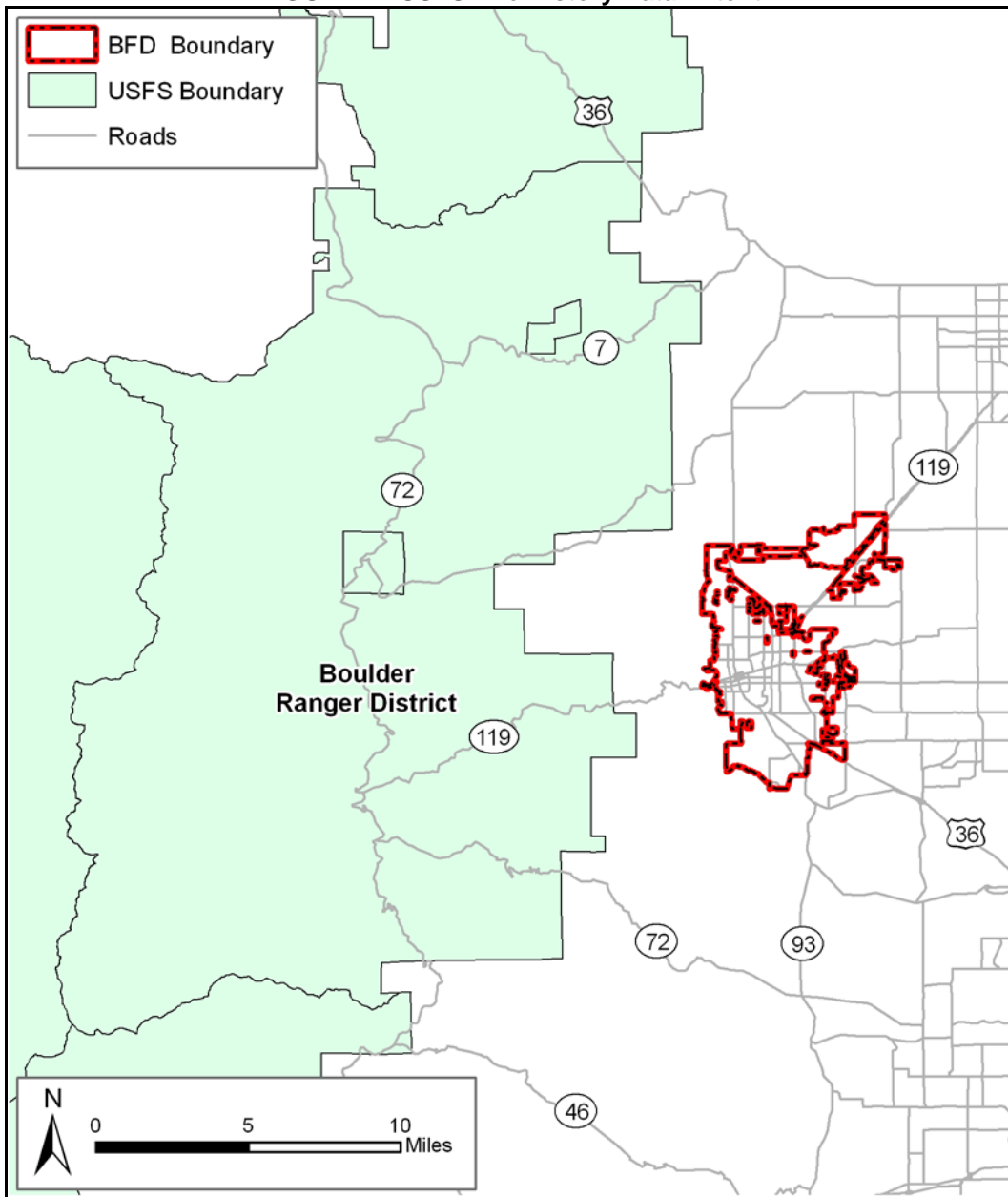
**Figure 6e** shows the number of fire starts for each day that a fire start was recorded. Most fires (299) occurred on days that only had one fire start. Approximately 8% (26) of fire days had two fire starts recorded and days with three or more fire starts represent less than 2% of all fire start days. The statistics suggest that multiple start days are a rare occurrence compared to fire days with a single ignition.

**FIGURE 6. USFS Fire Statistics (Boulder Ranger District)**



Size Class (in acres)	A	B	C	D	E	F	G		
	< ¼	¼ - 9	10 - 99	100-299	300-999	1000 - 4999	5000 +		
Causes	1	2	3	4	5	6	7	8	9
	Lightning	Equipment	Smoking	Campfire	Debris Burning	Railroad	Arson	Children	Misc.

**FIGURE 7. USFS Fire History Data Extent**



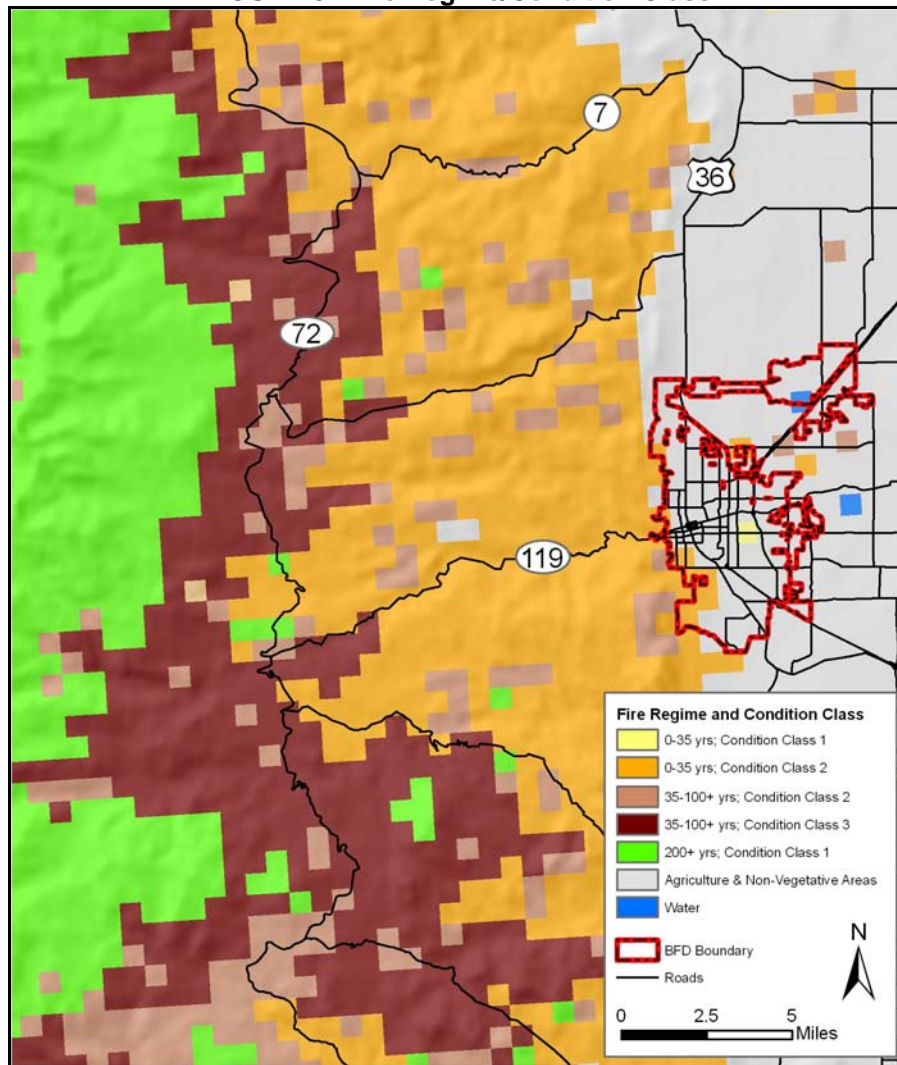
As the density of structures and the number of residents in the interface increases, possible ignition sources will multiply. Unless efforts are made to mitigate the potential for human ignition sources spreading to the surrounding forest, the probability of a large wildfire occurrence will undoubtedly increase.

### **Fire Regime Condition Class**

The Fire Regime Condition Class (FRCC) is a landscape evaluation of expected fire behavior as it relates to the departure from historic norms. The data used for this study is from a national level map. The minimum mapping unit for this data is 1 square kilometer. FRCC is not to be confused with BEHAVE and FlamMap fire behavior models (detailed in the fire behavior section) which provide the fire behavior potential analysis for expected flame length, rate of spread and crown fire development.

The FRCC is an expression of the departure of the current condition from the historical fire regime. It is used as a proxy for the probability of severe fire effects (e.g., the loss of key ecosystem components - soil, vegetation structure, species, or alteration of key ecosystem processes - nutrient cycles, hydrologic regimes). Consequently, FRCC is an index of hazards to the status of many components (e.g., water quality, fish status, wildlife habitats, etc.). **Figure 8** displays graphically the return interval and condition class of the study area.

**FIGURE 8. Fire Regime/Condition Class**




Deriving FRCC entails comparing current conditions to some estimate of the historical range that existed prior to substantial settlement by Euro-Americans. The departure of the current condition from the historical baseline serves as a proxy for probable ecosystem effects. In applying the condition class concept, it is assumed that historical fire regimes represent the conditions under which the ecosystem components within fire-adapted ecosystems evolved and have been maintained over time. Thus, if it is projected that fire intervals and/or fire severity have changed from the historical conditions, then it would be expected that fire size, intensity, and burn patterns would also be subsequently altered if a fire occurred. Furthermore, if it is assumed that these basic fire characteristics have changed, then it is likely that there would be subsequent effects to those ecosystem components that had adapted to the historical fire regimes.

As used here, the potential of ecosystem effects reflect the probability that key ecosystem components would be lost if a fire were to occur within the COB study area. It should be noted that a key ecosystem component can represent virtually any attribute of an ecosystem (for example, soil productivity, water quality, floral and faunal species, large-diameter trees, snags, etc.).

The following categories of condition class are used to qualitatively rank the potential of effects to key ecosystem components:

**TABLE 3. Condition Class Descriptions<sup>8</sup>**



<b>Condition Class</b>	<b>Condition Class Description</b>
1	Fire regimes are within their historical range and the risk of losing key ecosystem components as a result of wildfire is low. Vegetation attributes (species composition and structure) are intact and functioning within an historical range. Fire effects would be similar to those expected under historic fire regimes.
2	Fire regimes have been moderately altered from their historical range. The risk of losing key ecosystem components as a result of wildfire is moderate. Fire frequencies have changed by one or more fire-return intervals (either increased or decreased). Vegetation attributes have been moderately altered from their historical range. Consequently, wildfires would likely be larger, more intense, more severe, and have altered burn patterns, as compared with those expected under historic fire regimes.
3	Fire regimes have changed substantially from their historical range. The risk of losing key ecosystem components is high. Fire frequencies have changed by two or more fire-return intervals. Vegetation attributes have been significantly altered from their historical range. Consequently, wildfires would likely be larger, more intense, and have altered burn patterns, as compared with those expected under historic fire regimes.

The communities of the study area are dominantly classified under Condition Class 2. By definition, historic fire regimes have been moderately altered. Consequently, wildfires are likely to be larger, more severe, and have altered burn patterns, as compared with those expected under historic fire regimes.

<sup>8</sup> Fire Regime Condition Class, website, <http://www.frcc.gov/>, July 2005.

## **Fire Behavior Potential**

As a part of the wildfire hazard analysis carried out for this study, the fire behavior potential of the study area was modeled (see **Appendix A**). This model can be combined with the community wildfire hazard ratings (WHR), structure density and Values at Risk information to generate current and future “areas of concern.” **Figures 9-11** show the fire behavior potential for the analysis area, given the average weather conditions existing between May 1 and October 31. Weather observations from the Sugarloaf Remote Automated Weather Station (RAWS) were averaged for a thirty-year period (1977-2006) to calculate these conditions.

**Figures 12-14** show the fire behavior potential for the analysis area, given ninety-seventh percentile weather data. In other words, the weather conditions existing on the five most severe fire weather days in each season for the thirty-year period were averaged together to provide the weather data for this calculation. It is a reasonable assumption that similar conditions may exist for at least five days of the fire season during an average year. In fact, during extreme years such as 2000 and 2002, such conditions may exist for significantly longer periods.

Weather conditions are extremely variable and not all combinations are accounted for. These outputs are best used for pre-planning and not as a stand-alone product for tactical operations. This model can be combined with the WHR and Values at Risk information to generate current and future “areas of concern,” which are useful for prioritizing mitigation actions. It is recommended that when this information is used for tactical operations, fire behavior calculations be done with actual weather observations during the fire event. For greatest accuracy, the most current Energy Release Component (ERC) values should be calculated and distributed during the fire season to be used as a guideline for fire behavior potential. For a more complete discussion of the fire behavior potential methodology, please see **Appendix A**.

FIGURE 9. Flame Length, Moderate Conditions

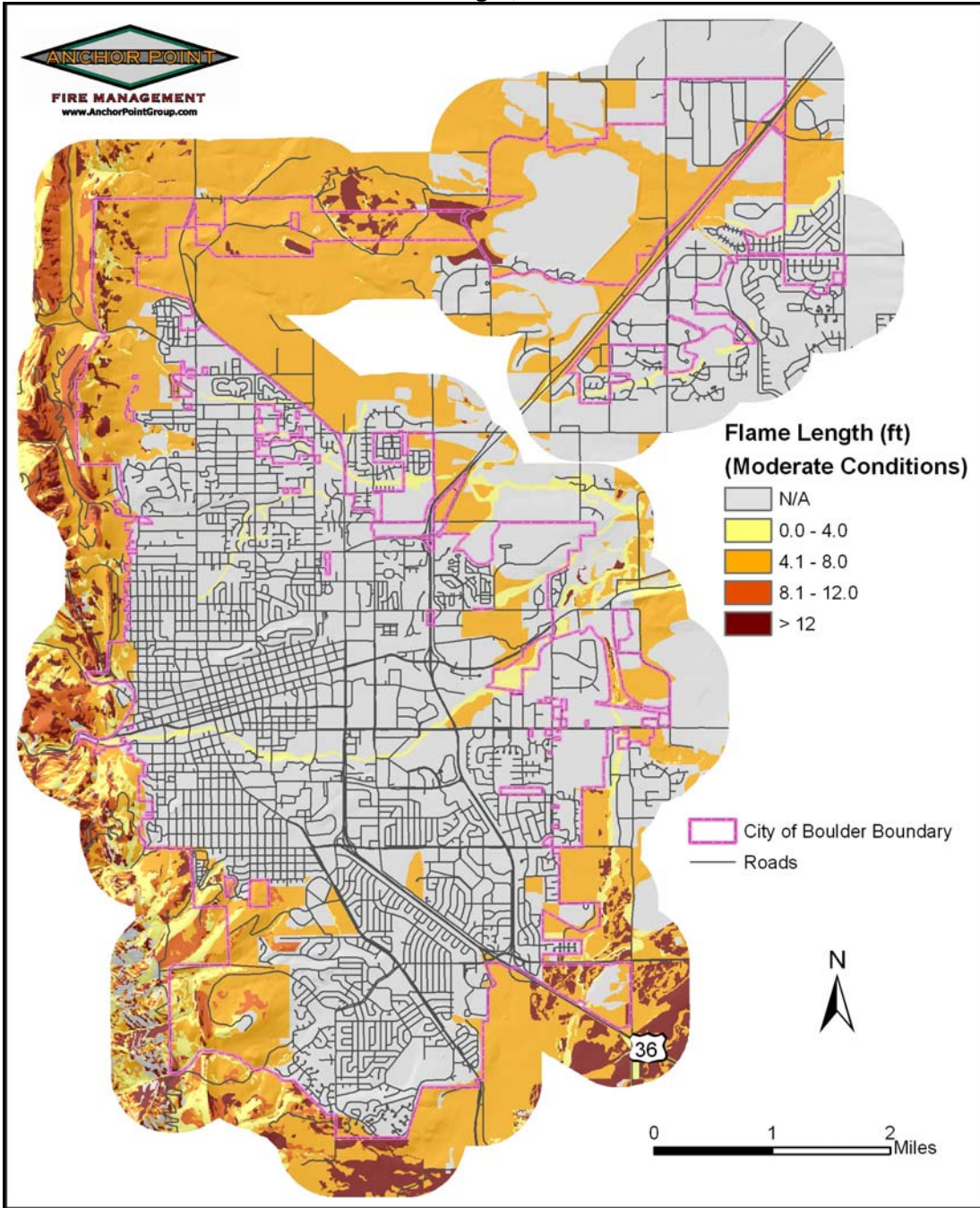




FIGURE 10. Rate of Spread, Moderate Conditions

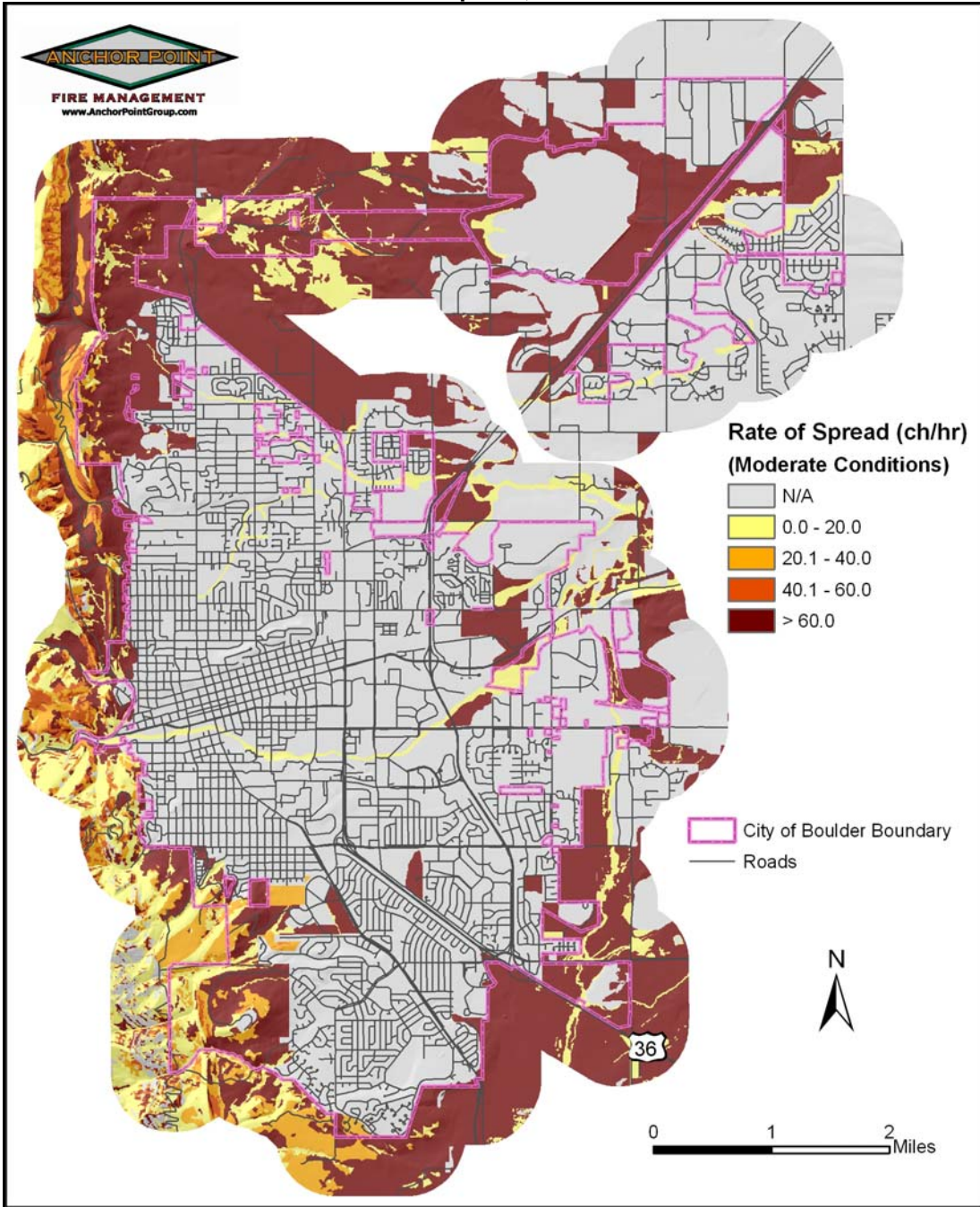


FIGURE 11. Crown Fire Potential, Moderate Conditions

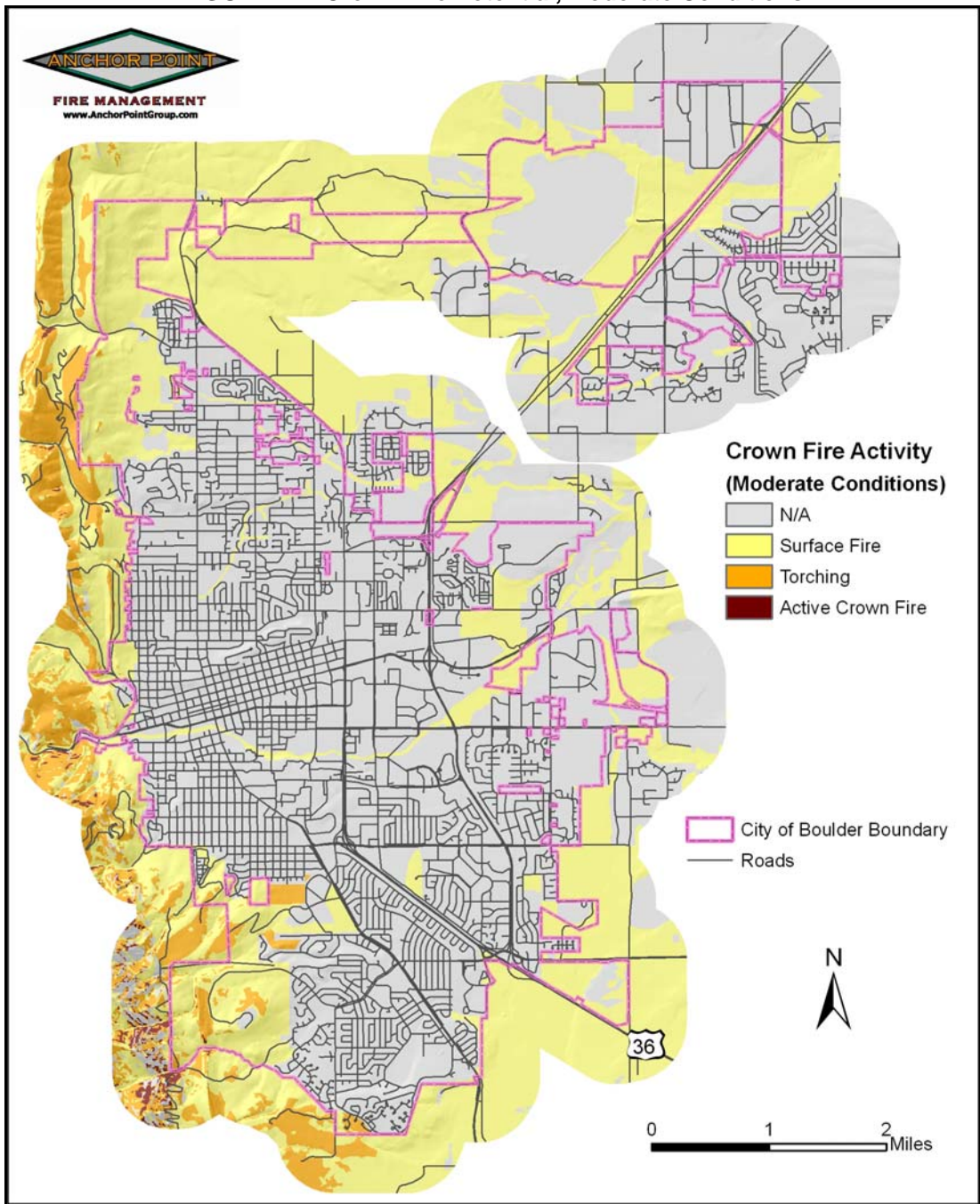


FIGURE 12. Flame Length, Extreme Conditions

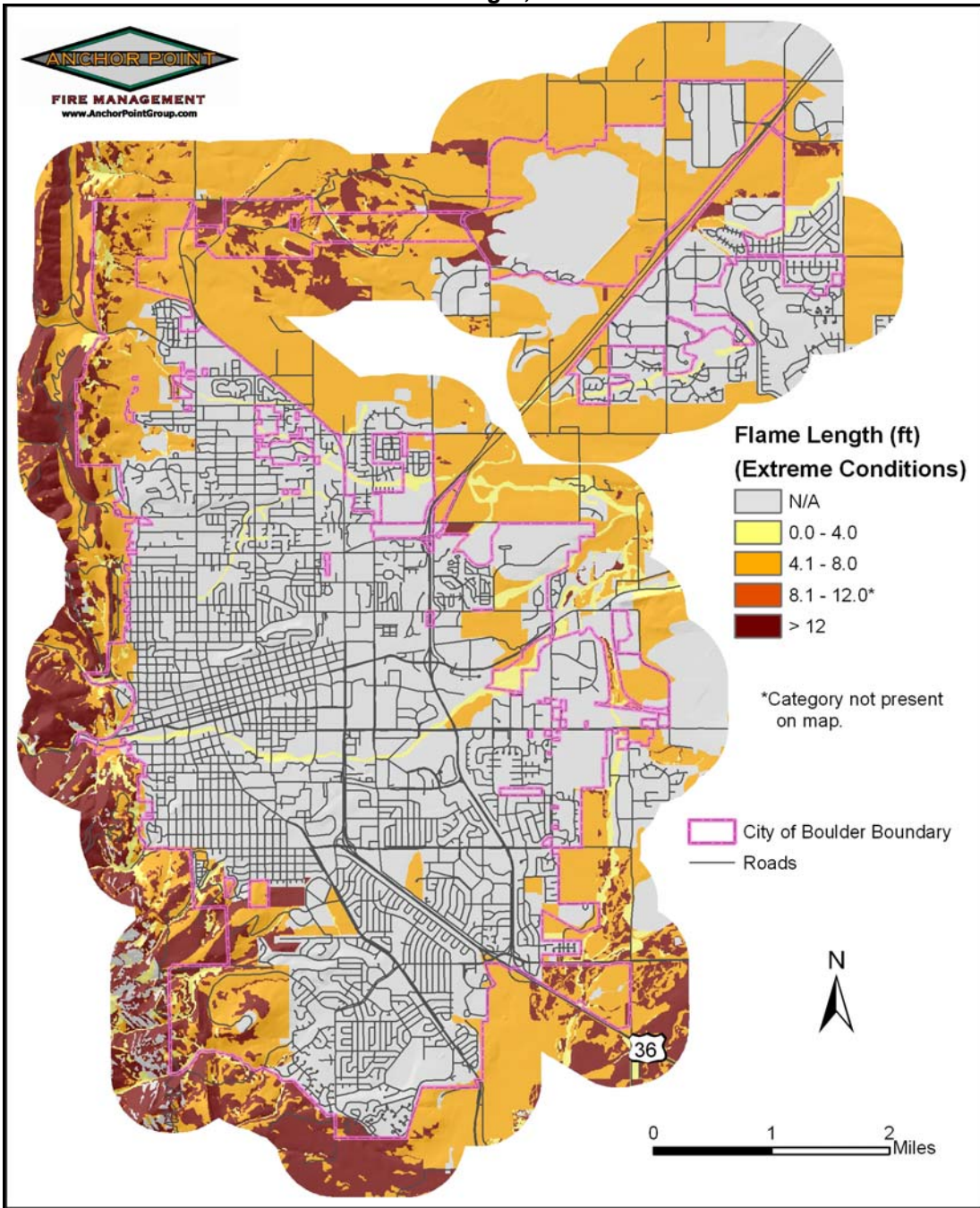


FIGURE 13. Rate of Spread, Extreme Conditions

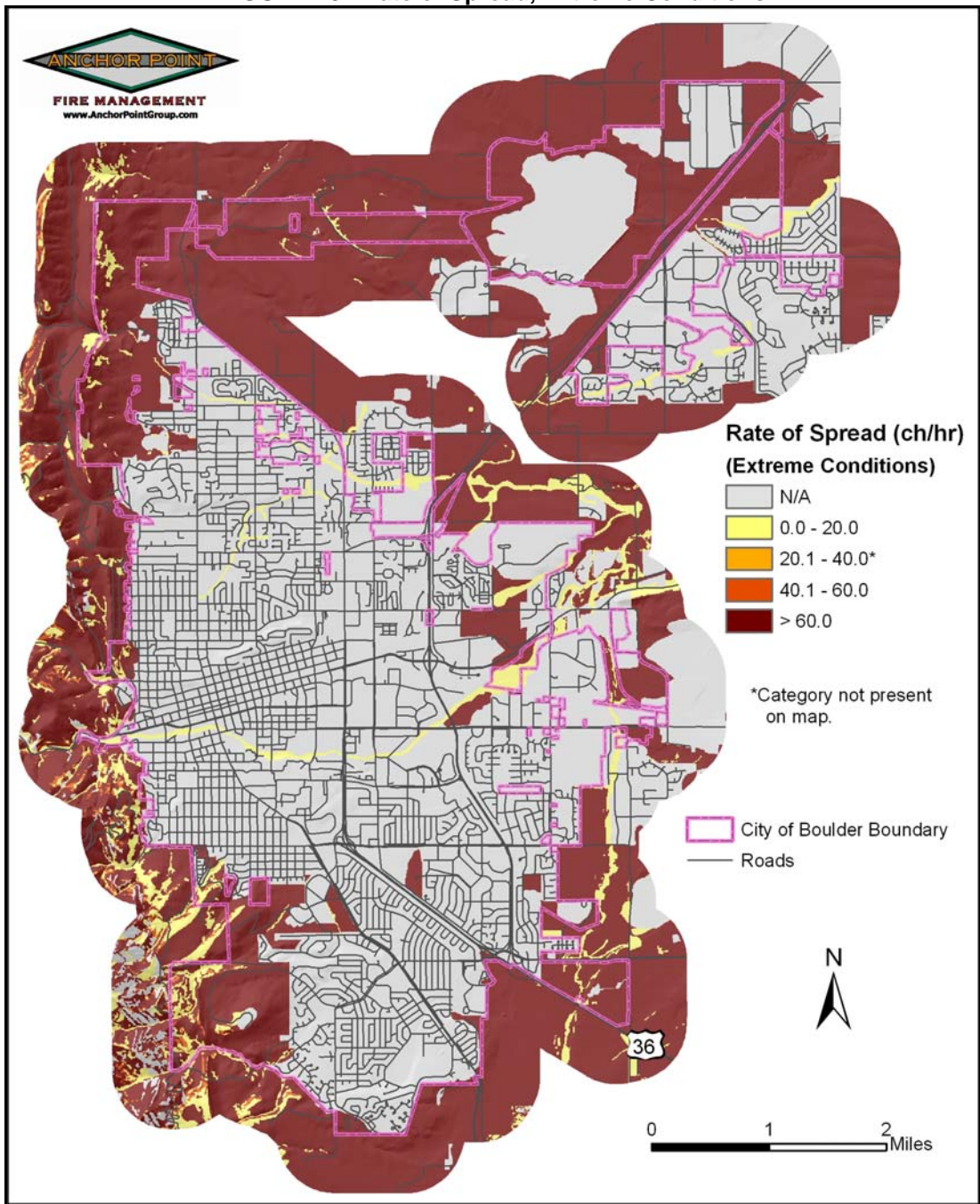
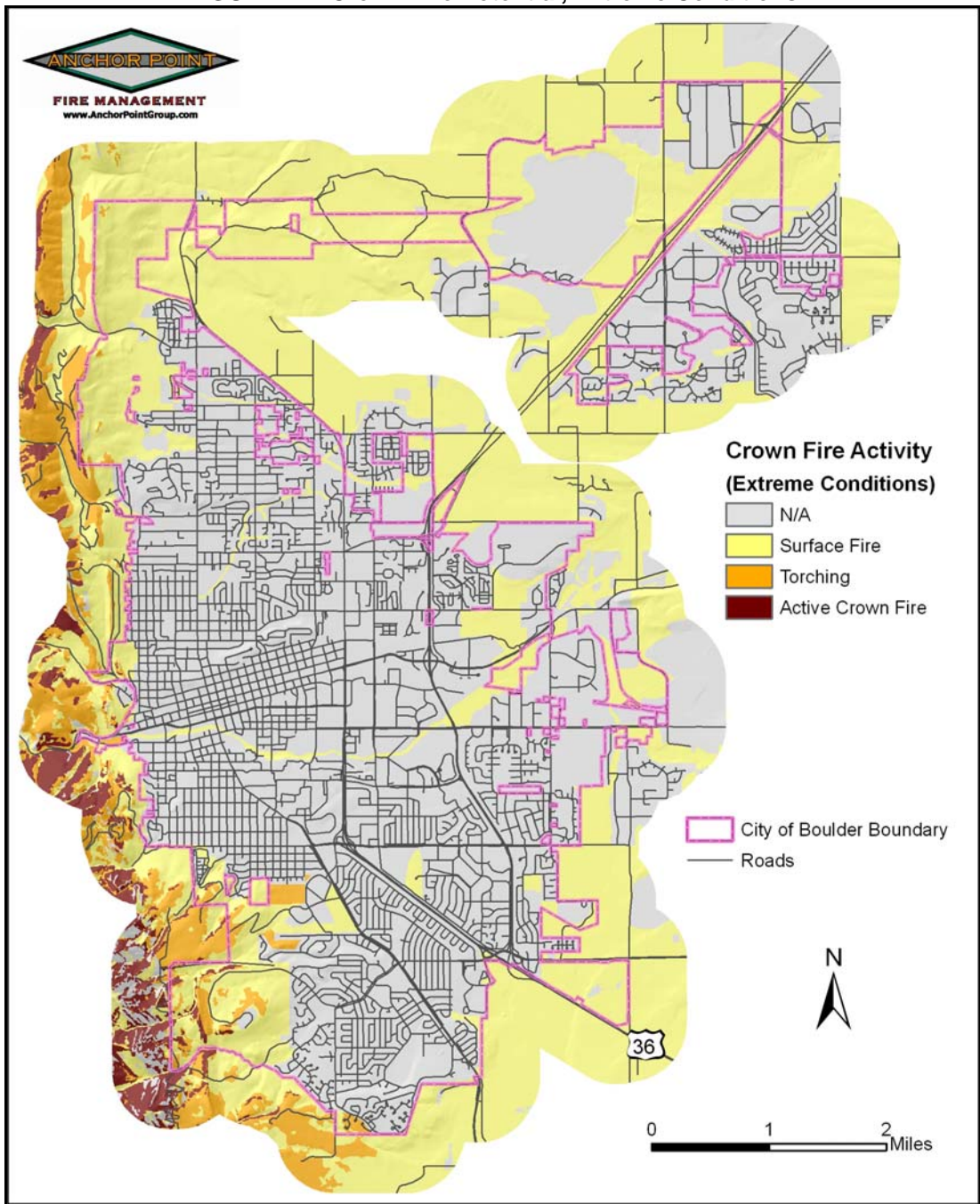


FIGURE 14. Crown Fire Potential, Extreme Conditions



## SOLUTIONS AND MITIGATIONS

---

### **Establishing and Prioritizing Fire Management Units (FMUs)**

An efficient method for prioritizing work efforts is to create FMUs. These units reflect a particular function, like developing an effective public outreach program, or a geographic treatment area, such as an area with related fuel reduction projects. FMUs are created prior to initiating management projects and mitigation activities. Unique activities and objectives are recommended for each unit. These solutions are designed to serve as proposed outlines for projects. They are presented as a starting point for communities to determine the priority and scope of the final project implementation. Local land and fire management agencies, with the input of the citizen's advisory council or fire safe council, must determine the final solutions.

The following FMUs have been identified for the City of Boulder, and recommendations are provided for each. FMUs are **not** ranked by priority, but priority recommendations have been provided for specific tactical mitigation actions where appropriate within FMUs.

- Safety Zones, Addressing, Access, and Evacuation Routes FMU
- Public Education FMU
- Local Preparedness and Firefighting Capabilities FMU
- Home Mitigation FMU
- Plains Communities FMU
- Fuels Modifications FMU
- Water Supply FMU

# SAFETY ZONES, ADDRESSING, ACCESS, AND EVACUATION ROUTES FMU

---

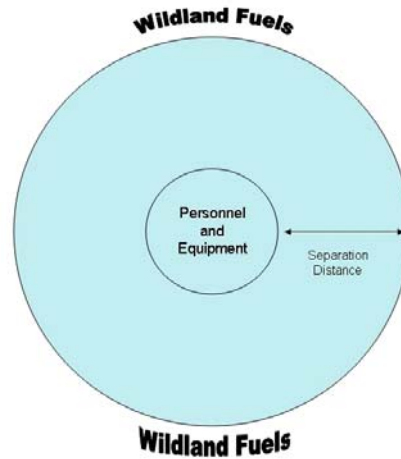
## Safety Zones

When pre-planning for a wildfire incident, designating safety zones for use by the responding firefighters should be a top priority. More than one safety zone is advised, because fire operations can be spread out over a large geographical area. When evaluating areas to be used, they must be easily accessible and adhere to current guidelines recommended by NWCG. (See **Figure 15**)

**FIGURE 15. Safety Zone Guidelines**

Flame Height	Distance Separation (firefighter to flame)	Area in Acres
10 feet	40 feet	1/10 acre
20 feet	80 feet	1/2 acre
50 feet	200 feet	3 acres
75 feet	300 feet	7 acres
100 feet	400 feet	12 acres
200 feet	800 feet	50 acres

(1 acre = 208 feet x 208 feet, or the approximate size of a football field)



Distance separation (minimum) is the radius from the center of the safety zone to the nearest fuels.<sup>9</sup>

## RECOMMENDATIONS:

There are numerous areas within close proximity to the interface communities that could serve as designated safety zones. Options would include large city parks, looped secondary streets, and business parking lots. These locations should be evaluated by City of Boulder personnel, and if viable inserted in the run books.

<sup>9</sup> <http://www.nwcg.gov/pms/pubs/410-1/chapter01.pdf> referenced March 20, 2007

## Addressing

Addressing overall within the City of Boulder is good. However, there are some areas that have poor and/or inconsistent street signage and addressing of properties. In the worst cases, addressing was missing altogether or attached to combustible objects. (See **Figure 16**.) Some of the interface areas in Boulder have very intricate roads and driveways. In these areas, proper, standardized, reflective signage is critical to effective response. Response times are substantially reduced, especially at night and in difficult conditions, by standardized addressing. Knowing at a glance the difference between a road and a driveway (and which houses are on the driveway) cuts down on errors and time wasted interpreting maps. This is especially true for city employees who have not had the opportunity to train on access issues as often as career emergency responders. Standardized reflective signage mounted on a non-combustible pole is highly recommended. These signs can be used in addition to the current markers.

Recommendations for address markers can be found in **Appendix D**.

**FIGURE 16.**

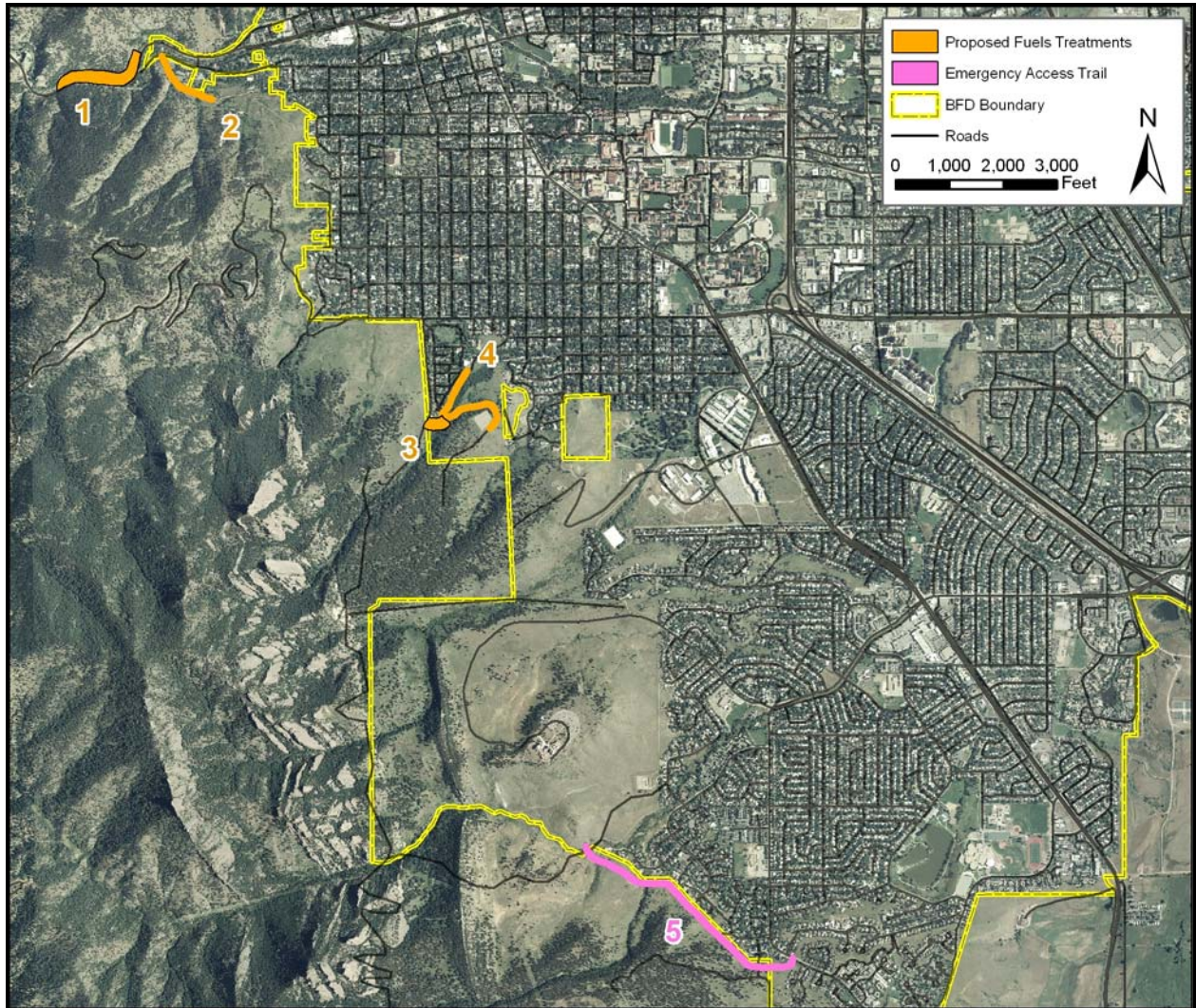




### Proposed Emergency Access Trail

The primary concern within the Shanahan West Area (**Very High Hazard rating**) is a lack of emergency access into open space. Currently there are several foot paths in the area, none of which would serve to assist with firefighting or other emergency situations. A proposed emergency access trail is highlighted as #5 in **Figure 17**.

**FIGURE 17.**



## **EMERGENCY ACCESS TRAIL RECOMMENDATIONS:**

---

The route is represented graphically by # 5 within **Figure 17**.

5. **Lehigh Street to Bear Creek trail. Priority Level High.** This project focuses on establishing an emergency access trail through the open space area beginning at Lehigh Street (between Hardscrabble Drive and Lafayette Drive) and running in a northwest direction to tie in to the Bear Creek trail. Portions of this trail would make use of existing footpaths, which would need to be widened. The trail surface should be able to support a type 6 engine (larger-sized four wheel drive vehicle). Fuels mitigation consisting of limbing and thinning to create a safe, effective escape route is also recommended (see the *Access Route Fuels Modification Projects* section of this report). This project might require a cooperative effort between the City and private landowners. It is recommended that the route be well marked. This emergency access trail could also be used as a regular recreation trail.

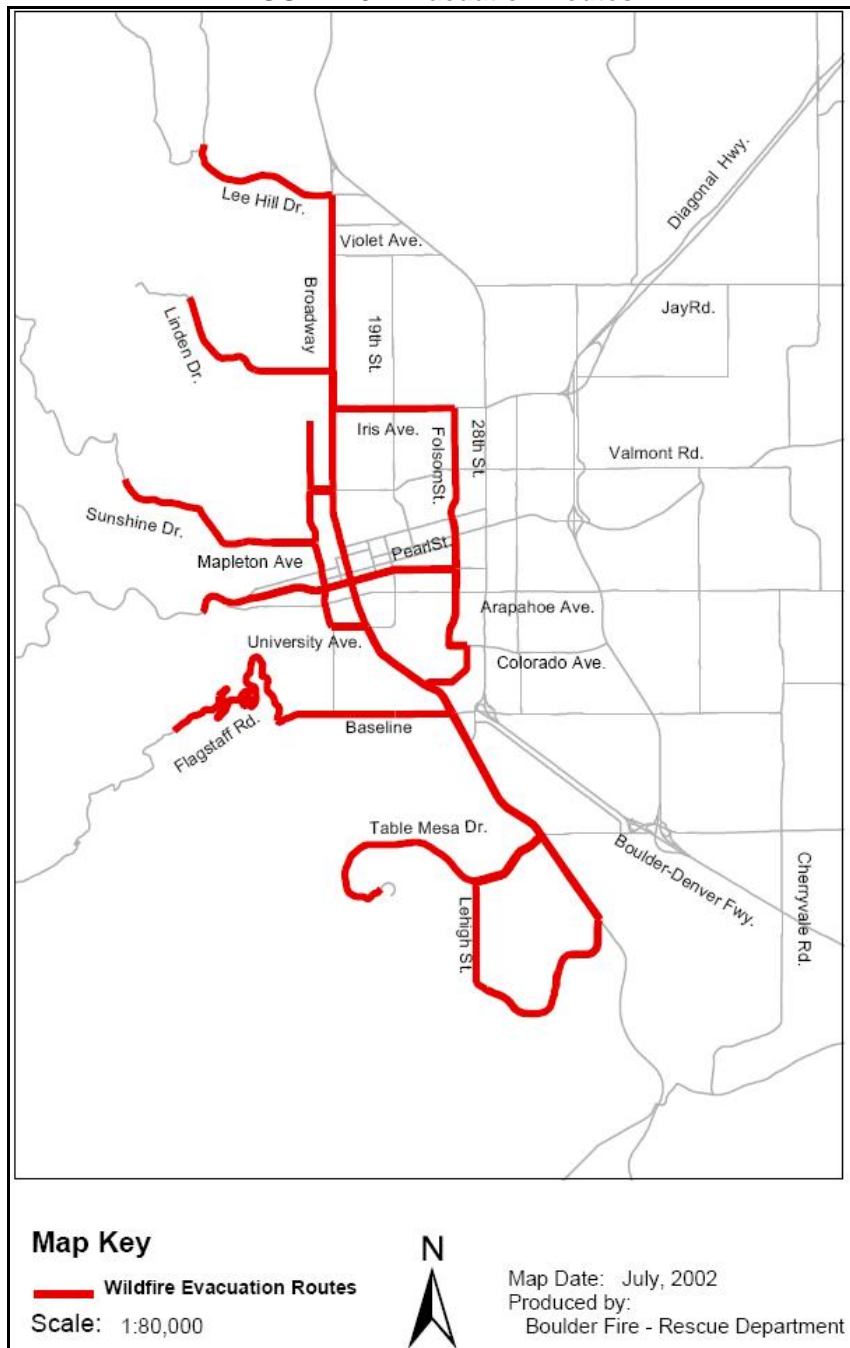
***A significant amount of effort should be devoted to educating the homeowners in this area about the importance of this project.***

- **Open Space Access Signage. Priority Level High.** All open space access points should be clearly marked both on-site and within the City emergency response map books. Access points that are secured from opening should have a common key, combination, or device (radio frequency activation, opticom, etc.) carried by all City responders.

## Evacuation Routes

Wildfire evacuation routes and recommendations have been pre-designated by City of Boulder officials prior to this report. These routes are highlighted in **Figure 18**.

**FIGURE 18. Evacuation Routes**



## **EVACUATION ROUTE RECOMMENDATIONS:**

---

### **Prepare**

**Evacuation Plan** - All family members need to know what to do if evacuated or unable to return home. Know local evacuation routes.

**House Address** - Make sure house numbers are visible from the street.

**Meeting Place** - Designate a meeting place away from home well known to family.

**Contact Person** - Choose an out-of-the-area contact person to relay information about your welfare to family and friends **and** to keep your phone lines open.

**Medical Needs** - Assemble prescription drugs, etc. for evacuation.

**Documents** - Collect birth certificates, social security cards, wills, account numbers, policies, securities, pictures, household inventory and portable valuables for easy evacuation.

**Pets** - Assemble pet-kit with food, leashes, and medicines for easy evacuation.

### **Evacuate**

**Evacuate Immediately** - Wildfire is unpredictable and moves fast!

**Contact Numbers** - Put a note on the door with your contact phone numbers so you may be located in the event firefighters need to reach you.

**Turn on outdoor house lights** - This helps firefighters locate your house.

**Shelter** - Shelter locations will be announced based on location of fire.<sup>10</sup>

---

<sup>10</sup> [http://bouldercolorado.gov/index.php?option=com\\_content&task=view&id=2408&Itemid=779](http://bouldercolorado.gov/index.php?option=com_content&task=view&id=2408&Itemid=779) referenced 08-16-07

## **OTHER GENERAL RECOMMENDATIONS:**

---

1. In order to reduce conflicts between evacuating citizens and incoming responders, it is desirable to have nearby evacuation centers for citizens and staging areas for fire resources. Evacuation centers should include heated buildings with facilities large enough to handle the population. Schools and churches are usually ideal for this purpose. Fire staging areas should contain large safety zones, a good view in the direction of the fire, easy access and turnarounds for large apparatus, a significant fuel break between the fire and the escape route, topography conducive to radio communications, and access to water. Local responders are encouraged to preplan the use of potential staging areas with property owners.
2. Identify and pre-plan alternate escape routes and staging areas.
3. Perform response drills to determine the timing and effectiveness of fire resource staging areas.
4. Educate citizens on the proper escape routes and evacuation centers to use in the event of an evacuation.
5. Use a reverse 911 system or call lists to warn residents when an evacuation may be necessary. Notification should also be carried out by local television and radio stations. Any existing disaster notification systems, such as tornado warnings, should be expanded to include wildfire notifications.
6. Emergency management personnel should be included in the development of preplans for citizen evacuation.
7. Post placards clearly marking "fire escape route." This will provide functional assistance during an evacuation and communicate a constant reminder of wildfire to the community. Be sure to mount signage on non-combustible poles, preferably under the street name sign. The placards should start from the furthest point into the subdivision and work outward. These placards greatly assist responding firefighters from other agencies who may not be familiar with the layout of the subdivision.

## Public Education FMU

The Boulder area is experiencing continuing development. Spiraling property values and a limited number of building sites have resulted in recently constructed, high-value residences mixed in with older homes, rental properties and historic buildings in various states of decay. There is likely to be a varied understanding among property owners of the intrinsic hazards associated with building in these areas. An approach to wildfire education that emphasizes safety and hazard mitigation on an individual property level should be undertaken, in addition to community and emergency services efforts at risk reduction. Combining community values such as quality of life, property values, ecosystem protection and wildlife habitat preservation with the hazard reduction message will increase the receptiveness of the public.

Field contacts and interviews indicate that some homeowners in the study area are very supportive and proactive regarding wildfire mitigation efforts. Unfortunately there are still homeowners and landowners who refuse to acknowledge the fact that they live in an area at risk for wildfires. Continued attempts to provide educational materials through personal contact should be conducted. Property owner education and the wildfire hazard mitigation message should be an ongoing effort throughout the front-range interface.

## RECOMMENDATIONS

---

- Visit these web sites for a list of public education materials, and for general homeowner education:
  - <http://www.nwccg.gov/pms/pubs/pubs.htm>
  - <http://www.firewise.org>
  - <http://csfs.colostate.edu/protecthomeandforest.htm>
  - <http://www.bouldercolorado.gov>
  
- Provide citizens with the findings of this study including:
  - Levels of risk and hazard
  - Values of fuels reduction programs
  - Consequences and results of inaction for ignitions within the community
  
- Create a Wildland Urban Interface (WUI) citizen advisory council to provide peer level communications for the community. Too often, government agency advice can be construed as self-serving. Consequently, there is poor internalization of information by the citizens. The council should be used to:
  - Bring the concerns of the residents to the prioritization of mitigation actions
  - Select demonstration sites
  - Assist with grant applications and awards
  
- Continue to offer the All-Hazards Symposium. This is sponsored by the City of Boulder and the County of Boulder Office of Emergency Management.
  - Provide updates to the CWPP recommendations
  - Provide and receive citizen information
  
- A number of public recreation areas are present within the City of Boulder, (see **Areas of Special Interest** below). One recommendation for those areas is to provide wildfire education to the public via verbal contact, published literature, and signage.

## Local Preparedness and Firefighting Capabilities FMU

The City of Boulder provides suppression services for the study area of this report.

- The fire department has seven career fire stations which service all types of emergency response including wildland fire. The Fire Department has a 16 member Wildland Fire Team; their qualifications range from Firefighter Type 2 to Division Supervisor.
- The Wildland Division of the Fire Department provides a supervisory staff of three and a seasonal fire/mitigation crew of 6. Their qualifications range from Firefighter Type 2 to Division Supervisor.
- The Open Space / Mountain Parks Department provide a seasonal mitigation crew of 4 and numerous other individuals (including Rangers) who are trained in wildland firefighting practices.

The City of Boulder maintains five type-1 engines, four type-6 brush trucks, two type-3 engines/ water tenders, five aeriels, one rescue, and one command vehicle. These apparatus are a mixture of hard and soft staffed. Not all of the above-mentioned apparatus respond from fire stations; in some cases, operators must first respond to a remote vehicle storage building to retrieve the apparatus.

As mentioned in other sections of this CWPP, the City of Boulder has taken pro-active steps in preplanning their WUI response areas. Good mapping coupled with individual home assessments is a critical step to attaining successful fire outcomes.

City of Boulder firefighters are trained and experienced in wildland fire. The city adheres to the National Wildfire Coordinating Group (NWCG) curriculum for training.

Several City of Boulder personnel possess more advanced wildfire qualifications and respond to wildfire incidents across the country. The experience they gain while assigned to large ongoing wildfire incidents provides numerous and important benefits. These benefits will greatly enhance the effectiveness of the City of Boulder when confronted with larger incidents.

Mutual aid is available from numerous other fire suppression agencies within Boulder County. It is also important to note that the City of Boulder contracts with a number of these agencies to provide fire protection to city lands outside of the study area focused on in this report. The following agencies provide aid to the City of Boulder: the Rocky Mountain Fire Protection District, Boulder Rural Fire Protection District, Lefthand Fire Protection District, Four Mile Fire Protection District, Boulder Mountain Fire Protection District, Sunshine Fire Protection District, Sugarloaf Fire Protection District, Hygiene Fire Protection District, Mountain View Fire Protection District, Coal Creek Fire Protection District, Indian Peaks Fire Protection District, Nederland Fire Department, Louisville Fire Department.

## RECOMMENDATIONS:

---

- Firefighter Training (**Priority Level High**): Provide education and experience for all firefighters including:
- NWCG S-130/190 for all Fire Department and OSMP personnel.
- Annual wildland fire refresher for all Fire Department and OSMP personnel.
- Annual “pack testing” (physical standards test) for firefighters who are required to remain wildfire qualified in a position.

- Organize and facilitate an annual wildfire interface training exercise within the communities outlined in this CWPP.
- S-215 Fire Operations in the Urban Interface
- S-290 Intermediate Fire Behavior
- I-200 and I-300 – Basic and Intermediate ICS
- Encourage personnel to seek higher wildfire qualifications.
- Encourage personnel to participate in out of district wildfire assignments.
- Encourage prescribed burn participation.
- Encourage Type 3 incident management group participation and utilization.

#### **Equipment:**

- **Priority Level High.** House all wildfire apparatus in career fire stations. This will allow for a quicker 24/7 response.
- **Priority Level High.** For the Fire Department firefighters, provide gear bags for both wildland and bunker gear to be placed on apparatus responding to fire calls. This will help ensure that firefighters have both bunker gear and wildland PPE available when the fire situation changes.
- **Priority Level Moderate.** Purchase and equip two CDF style type 3 engines for interface firefighting. This engine should be equipped with a “light” structural complement (SCBA, TIC, etc.) so it can function (in a limited capacity) as a piece of structure apparatus.

#### **Communications:**

- **Priority Level High.** Acquire an 800 MHz / VHF interoperability “black box.” This device quickly permits the user to patch together multiple radio frequencies into one common channel.

#### **Miscellaneous:**

- **Priority Level Moderate.** Combine the Fire Department and OSMP seasonal fire/mitigation crews together. They could still be split into squads for daily project work, but the overall operating mode would be that of a handcrew/module to foster crew cohesiveness.
- **Priority Level High.** Ensure that the Wildland Urban Interface Address Map books are updated annually to include the individual home assessments. Every piece of apparatus (FD & OSMP) and all mutual aid agencies will need a copy. Supervisor vehicles will need multiple copies or the ability to generate multiple copies; this will allow for the distribution of specific maps to incoming mutual aid resources that may not have the most current maps.
- **Priority Level High.** The Wildfire Evacuation Information presented on the City of Boulder web site needs to be updated and improved.



## Home Mitigation FMU

Community responsibility for self-protection from wildfire is essential. Educating homeowners is the first step in promoting shared responsibility. Part of the educational process is defining the hazard and risks both at the community- and at the parcel-level.

The community-level assessment identified six of the ten communities in the study area that are at very high or high risk. Construction type, condition, age, fuel loading of the structure/contents, and position are all contributing factors that make homes more susceptible to ignition under even moderate burning conditions. There is also a likelihood of rapid fire growth and spread in these areas, due to fast burning or flashy fuel components and other topographic features that contribute to channeling winds and promotion of extreme fire behavior.

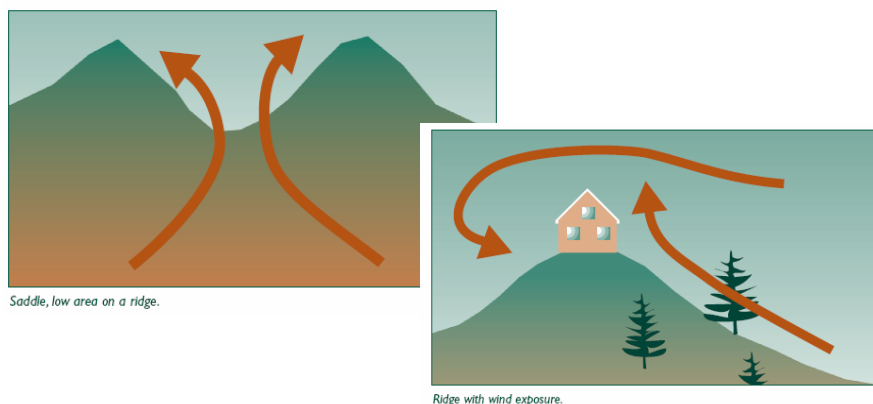
**Table 3** illustrates the relative hazard rankings for communities in the study area.

- A rating of eleven or less indicates an area of extreme hazard.
- A rating of 12 to 19 indicates a very high hazard.
- A rating of 20 to 25 indicates high hazard.
- A rating of 26 to 29 indicates moderate hazard.
- A rating of 30 or greater indicates a low hazard.

The communities with very high and high hazard ratings should be considered an FMU, where a parcel-level analysis should be implemented as soon as possible. For the communities that have already received a parcel-level analysis, a re-evaluation should be conducted if the analysis is more than 5 years old. Please see **Appendix B** for more detailed information.

**The most important element for the improvement of life safety and property preservation for every home in the study area is compliant, effective defensible space.** This is especially important for homes with wood roofs and homes located on steep slopes, in chimneys, saddles, or near any other topographic feature that contributes to fire intensity.

**FIGURE 19. Saddle & Ridge Top Development**<sup>11</sup>



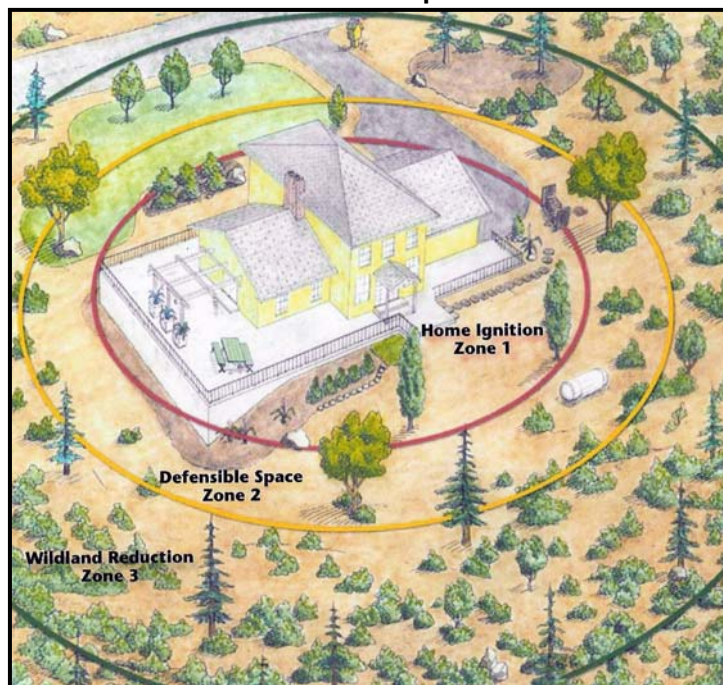
<sup>11</sup> FireWise Construction, Peter Slack, Boulder, Colorado

**An aggressive program of evaluating and implementing defensible space for homes will do more to limit fire-related property damage than any other single recommendation in this report.**

There is no question that any type of dense/flammable vegetation should be removed from around a home in order to reduce the risk of structural ignition during a wildfire. The question is how much should be removed? The basic rule is to eliminate all flammable materials (fire-prone vegetation, wood stacks, wood decking, patio furniture, umbrellas, etc.) from within 30 feet of the home. For structures near wildland open space, an additional 70 feet should be modified in such a way as to remove all dead wood from shrubbery, thin and trim trees and shrubs into "umbrella" like forms (lower limbs removed), and prevent the growth of weedy grasses (see **Figure 20**). Steep slopes and/or the presence of dangerous topographic features as described above may require the defensible space distances to be increased.

The term "clearance" leads some people to believe that all vegetation must be removed down to bare soil. This is not the case. Removing all vegetation unnecessarily compromises large amounts of forested terrain, increases erosion, and will encourage the growth of weeds in the newly disturbed soil. These weeds are considered "flashy fuels," which actually increase fire risk because they ignite so easily. Defensible space must be ecologically sound, aesthetically pleasing, and relatively easy to maintain. Only then will the non-prescriptive use of fuels reduction around homes become commonplace.

**FIGURE 20. Defensible Space Zones**<sup>12</sup>



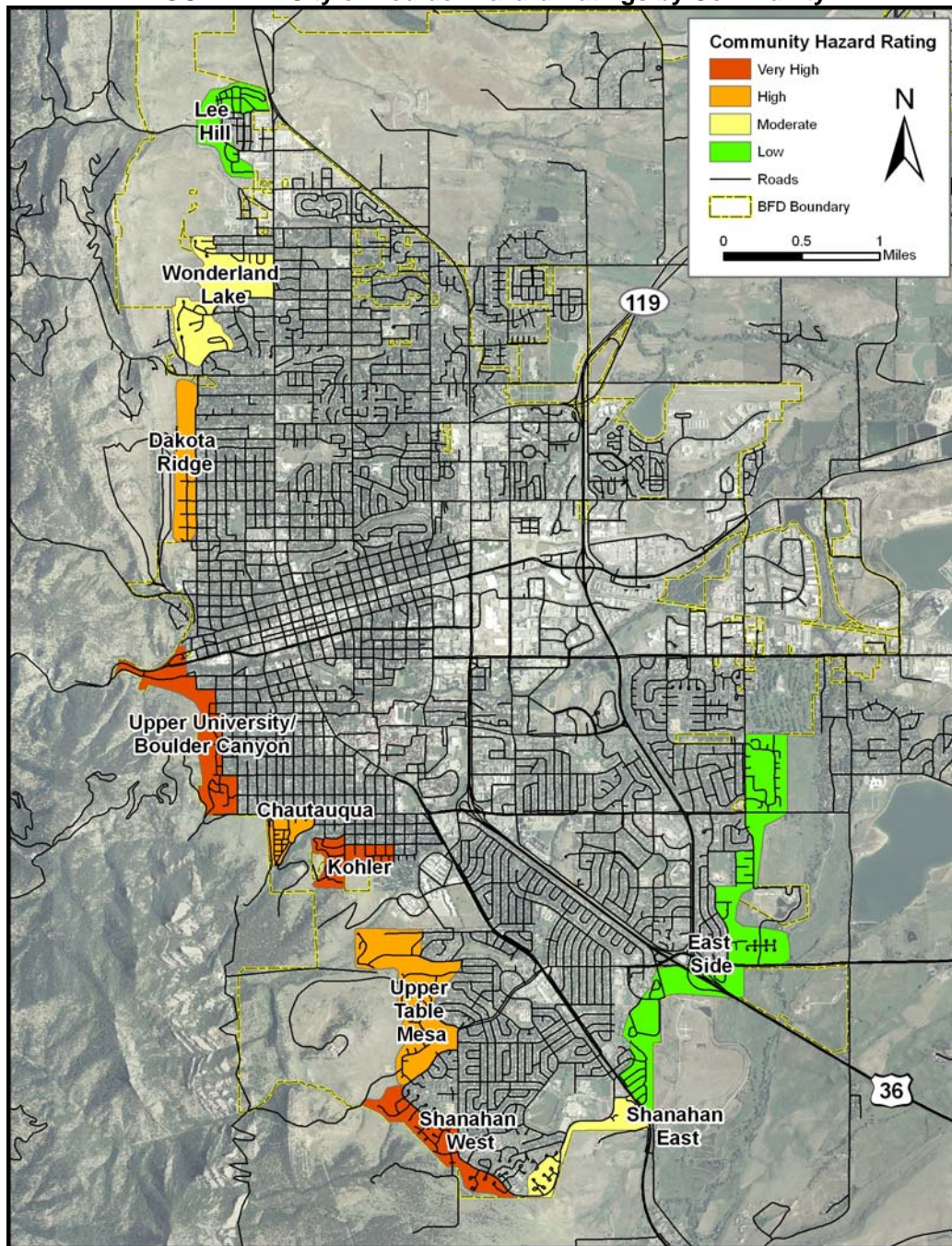
12 A Homeowner's Guide to Fire Safe Landscaping(2005) www.FireSafeCouncil.org

## RECOMMENDATIONS

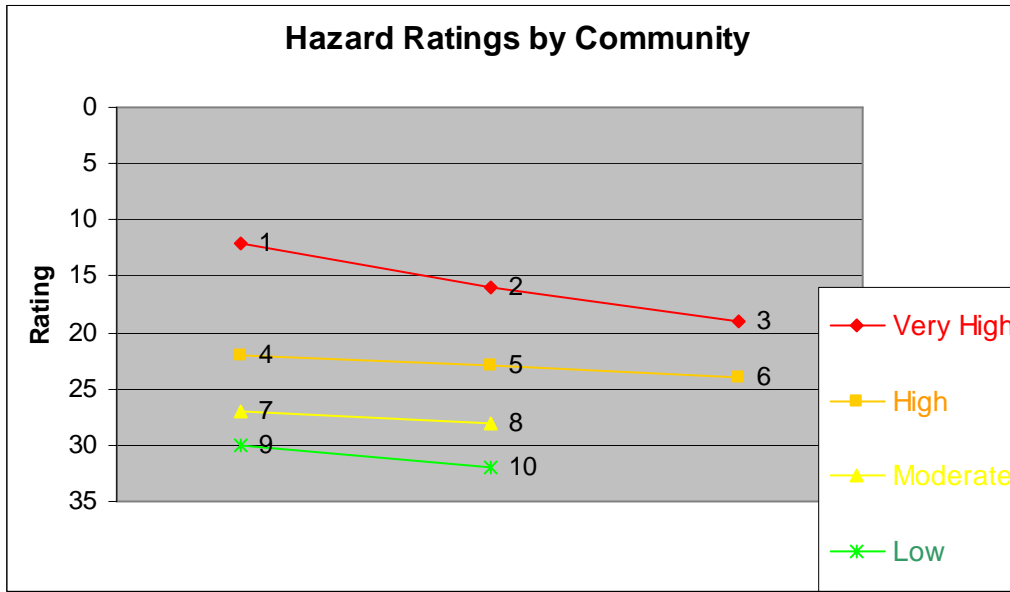
---

- **Priority level-High.** Conduct/re-conduct (if the analysis is more than 5 years old) a parcel-level wildfire hazard analysis for the homes in the communities within the study area that have been rated very high and high. Completing this process will facilitate the following important fire management practices:
  - Establishing a baseline hazard assessment for homes in these communities
  - Education of the community through the presentation of the parcel level Hazard-Risk Analysis at neighborhood public meetings
  - Identification of defensible space needs and other effective mitigation techniques
  - Identification and facilitation of “cross-boundary” projects
  - Community achievement of national FIREWISE status
  - Development of a Pre-Attack/Operational Plan for the FMU, and eventually the entire study area. A pre-attack plan assists fire agencies in developing strategies and tactics that will mitigate incidents that occur
- **Priority level-High.** Ensure that reflective address signs are present. Some homes will need signs at both the home and driveway. (See **Appendix D** for recommendations).
- **Priority level-High.** Use the structure triage methodology provided in **Appendix C** to identify homes not likely to be defensible.
- **Priority level-High.** Improve access streets and turnarounds to create safe access for firefighting resources. This is of significant importance within the Kohler Area, Upper University/Boulder Canyon Area, and Dakota Ridge Area communities. See *Access and Addressing* (**Appendix D**).

FIGURE 21. City of Boulder Hazard Ratings by Community



**Table 4. City of Boulder Hazard Ratings by Community**



<b>1. Kohler Area</b>	<b>6. Dakota Ridge Area</b>
<b>2. Upper University / Bldr. Canyon Area</b>	<b>7. Wonderland Lake Area</b>
<b>3. Shanahan West Area</b>	<b>8. Shanahan East Area</b>
<b>4. Chautauqua</b>	<b>9. East Side Area</b>
<b>5. Upper Table Mesa Area</b>	<b>10. Lee Hill Area</b>

## Plains Communities FMU

There are some communities in the study area that are not representative of a true Wildland-Urban Interface, but are adjacent to, or in close proximity to, significant wildland fuel beds. These fuel beds consist of primarily tall grass prairie remnants and short grasses. Shrubs and hardwoods are also found growing in stringers and patches in drainages and riparian areas. There are some areas with jackpots of heavier fuels, most of which are smaller than the minimum mapping unit of the fire behavior model. Most of these fuels are located on open space parcels, and while some are grazed on a rotating basis, they represent a potential threat to some or most of the homes in these communities, especially those directly adjacent to them.

These communities generally have low to flat topography, but ravines and short run slopes exist in some areas. Agricultural properties and larger rural lots are mixed in with suburban style subdivisions throughout this area. Construction type and structure age varies widely with both ignition resistant-construction and homes with flammable roofs and sidings often existing in the same neighborhood. Although these communities have been given a low hazard rating, there are general mitigation measures which should be considered to reduce the possibility of loss resulting from fires occurring in the neighboring natural fuels. Homes located on the perimeter of these communities, or otherwise adjacent to continuous areas of natural fuels, are the highest priority for mitigation. The following recommendations should be considered for the East Side Area community.

## RECOMMENDATIONS

---

- Defensible space is recommended for all homes. Maintain defensible space throughout the year.
  - ✓ Mow grass and weeds to a low height.
  - ✓ Clean needle litter from roofs and gutters and away from foundations.
  - ✓ Do not dispose of yard waste into open space areas.
  - ✓ Discourage the planting of flammable vegetation such as juniper within 30 feet of homes.
  - ✓ Encourage the use of xeriscaping, and use fire- and drought-tolerant plants for ornamental plantings, especially within 30 feet of homes (see **Home Mitigation FMU**).
  - ✓ Water ornamental vegetation during times of drought.
  - ✓ When possible, maintain an irrigated green belt around the home.
- Extended defensible space is recommended for all homes located on the perimeter of native fuel beds, especially those located near ravines, steep slopes, or other dangerous topographic features. These areas are also noted in **Appendix B**
- Wood shake and other flammable roofing types should be replaced with ignition-resistant roofing such as asphalt or metal (see the **Home Mitigation FMU** section of this report).
- Encourage the use of low-combustibility materials for decks and projections on new construction and renovations, especially where homes are upslope from heavy fuels.
- Do not store combustibles or firewood under decks. Open areas below decks, outdoor stairways, and homes should be enclosed or screened to prevent the ingress of embers,

especially where such openings are located on slopes above natural (non-irrigated, non-maintained) vegetation.

- Trees along driveways should be limbed and thinned as necessary to maintain clearance for emergency vehicle access (13' 6" vertically and 16' horizontally).
- Power pole bases should be surrounded by an area at least 5' in diameter that is completely free of flammable vegetation.

# FUELS MODIFICATION PROJECTS FMU

---

## Introduction

One of the most effective forms of landscape-scale fuels modification is the fuelbreak (sometimes referred to as “shaded fuelbreak”). A fuelbreak is an easily accessible strip of land of varying width (depending on fuel and terrain) in which fuel density is reduced, thus improving fire control opportunities. Vegetation is thinned, removing diseased, fire-weakened, and most standing dead trees. Thinning should select for the more fire-resistant species. Ladder fuels, such as low limbs and heavy regeneration, are removed from the remaining stand. Brush, dead and down materials, logging slash, and other heavy ground fuels are removed and disposed of to create an open park-like appearance. The use of fuelbreaks under normal burning conditions can limit the uncontrolled spread of fires and aid firefighters in slowing the spread rate. Under extreme burning conditions, where spotting occurs for miles ahead of the main fire, and probability of ignition is high, even the best fuelbreaks are not effective. Nonetheless, fuelbreaks have proven to be effective in limiting the spread of crown fires in Colorado.<sup>13</sup> Factors to be considered when determining the need for fuelbreaks in mountain subdivisions include:

- The presence and density of hazardous fuels
- Slope
- Other hazardous topographic features
- Crowning potential
- Ignition sources

With the exception of Aspen, all of Colorado’s major timber types represent a significant risk of wildfire. Increasing slope causes fires to move from the surface fuels to crowns more easily, due to preheating. A slope of 30% causes the fire-spread rate to double when compared to the fire-spread rate (with the same fuels and conditions) on flat ground. Chimneys, saddles, and deep ravines are all known to accelerate fire spread and influence intensity. Communities with homes located on or above such features, as well as homes located on summits and ridge tops, are good candidates for fuel breaks. Crown fire activity values for City of Boulder were generated by the FlamMap model and classified into four standard ranges. In areas where independent and dependent crown fire activity is likely to exist, fuelbreaks should be considered. If there are known likely ignition sources (such as railroads and recreation areas that allow campfires) present in areas where there is a threat of fire being channeled into communities, fuelbreaks should be considered.

Fuelbreaks should always be connected to a good anchor point, like a rock outcropping, river, lake, or road. The classic location for fuelbreaks is along the tops of ridges, in order to stop fires from backing down the other side or spotting into the next drainage. This is not always practical from a WUI standpoint, because the structures firefighters are trying to protect are usually located at the tops of ridges or mid-slope. Mid-slope positioning is considered the least desirable for fuelbreaks, but it may be easiest to achieve as an extension of defensible space work or off existing roads and escape routes. One tactic would be to create fuelbreaks on slopes below homes located mid-slope and on ridge tops, so that the area of continuous fuels between the defensible space of homes and the fuelbreak is less than ten acres. Another common tactic is to position fuelbreaks along the bottom of slopes. It would make sense to locate fuelbreaks mid-slope below homes to break the continuity of fuels into the smaller units

---

13 Frank C. Dennis, “Fuelbreak Guidelines for Forested Subdivisions” (Colorado State Forest Service, Colorado State University, 1983), p. 3.



mentioned above, even though this position is considered the least desirable from a fire suppression point of view.

Fuelbreaks are often easiest to construct along existing roadbeds (see the description of the fuels modification project for access routes on page 42 of this report). The minimum recommended fuelbreak width is usually 200 feet. As spread rate and intensity increases with slope angle, the size of the fuelbreak should also be increased, with an emphasis on the downhill side of the roadbed or centerline employed. The formulas for slope angles of 30% and greater are as follows: below road distance =  $100' + (1.5 \times \text{slope } \%)$ , above road distance =  $100' - \text{slope } \%$  (see **Table 4**). Fuelbreaks that pass through hazardous topographic features should have these distances increased by 50%.<sup>14</sup> Since fuelbreaks can have an undesirable effect on the aesthetics of the area, crown separation should be emphasized over stand density levels. In other words, isolating groupings rather than cutting for precise stem spacing will help to mitigate the visual impact of the fuelbreak.

In Colorado's dry climate, slash decomposes very slowly. One consequence of failing to remove slash is to add to the surface fuel loading, potentially making the area more hazardous than before treatment. It is imperative to dispose of all materials by piling and burning, chipping, physical removal from the area, or lopping and scattering. Of these methods, lopping and scattering is the cheapest, but also the least effective, since it adds to the surface fuel load.

Fuelbreaks must be maintained to be effective. Thinning usually accelerates the process of regenerative growth. The effectiveness of the fuelbreak may be lost in as little as three to four years if ladder fuels and regeneration are not controlled.

Securing the cooperation and participation of landowners is typically one of the most difficult issues in establishing and maintaining fuelbreaks. Ownership maps of the area indicate that implementation of fuels reduction projects recommended here would require the approval of public land management agencies as well as private landowners.

---

<sup>14</sup> Frank C. Dennis, "Fuelbreak Guidelines for Forested Subdivisions" (Colorado State Forest Service, Colorado State University, 1983), p. 11.

## ACCESS ROUTE FUELS MODIFICATION RECOMMENDATIONS

---

Road side thinning should include an area of at least 100' on either side of the centerline of the route, where practical. This distance should be modified to account for increased slope and other topographic features that increase fire intensity (see **Table 5**). This is especially important in communities with steep, narrow roads and few turnouts. In these areas, safer access for firefighters would make an impact on the number of structures that could be defended in a wildfire. Existing and natural barriers to fire should be incorporated into the project dimensions.

The cooperation of adjacent, contiguous landowners should be secured. If this is not possible, more intensive thinning may need to occur within the road easement. Landowner participation allows the project to be more flexible in selecting trees for removal. It allows greater consideration for the elements of visual screening and aesthetics. Enlarging the project dimensions allows more options for tree selection, while still protecting the access/egress corridor.

Elements of the fuels modification space for access and egress routes should include:

- Tree crown separation of at least 10' with groups of trees and shrubs interspersed as desired.
- Tree crown separation greater than 10' may be required to isolate adjacent groups or clumps of trees.
- Limb all remaining trees to a height of 8' or 1/3 of the tree height (whichever is greater).
- Clean up ground fuel within the project area.

**TABLE 5. Recommended Treatment Distances For Mid-Slope Roads**

<b>% Slope</b>	<b>Distance Above Road</b>	<b>Distance Below Road</b>
<b>30</b>	<b>70 feet</b>	<b>145 feet</b>
<b>35</b>	<b>65 feet</b>	<b>153 feet</b>
<b>40</b>	<b>60 feet</b>	<b>160 feet</b>
<b>45</b>	<b>55 feet</b>	<b>168 feet</b>
<b>50</b>	<b>50 feet</b>	<b>175 feet</b>

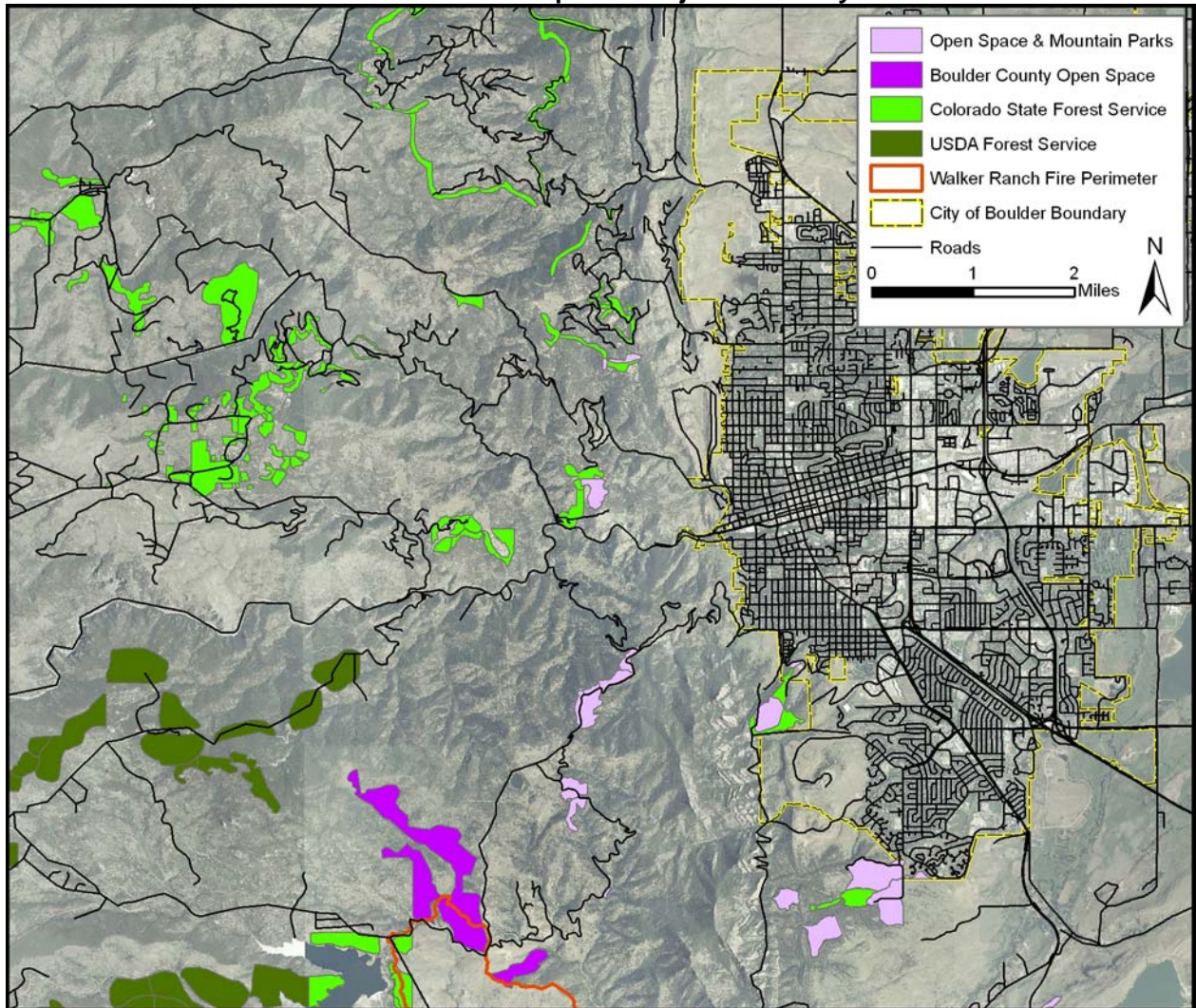
## Current and Proposed Cross-Boundary Projects

A very important purpose of this CWPP is to make known fuel reduction projects which may affect the City of Boulder interface areas. Below are descriptions of proposed projects contained in bordering agencies CWPP's. **Figure 21** shows some other known projects. Their last known status is in question, and as always, thorough "ground truthing" should be undertaken before planning begins on future projects. Where cross boundary projects exist, the City of Boulder should combine efforts with other agencies, so projects may be completed in a timely manner. This will ultimately serve to protect communities within the City of Boulder.

- **Kneale Road to Bison Drive via the "Gas Line Road."** This RMF draft CWPP project focuses on opening up the Gas Line Road for emergency usage from Kneale Road where it leaves the South Boulder Creek northward along the Gas Line Road to the Ethel Harrold Trailhead via Martin Gulch. This emergency usage would be for both citizens and emergency responders. The road surface should be evaluated to determine the feasibility of allowing non-four wheel drive vehicles in and out of the area. Road pullouts will also need to be constructed. This project will require a cooperative effort between RMF and Boulder County Open Space.
- **Chapman Drive to Boulder Canyon Drive.** This RMF draft CWPP project is meant to enhance fire access to the area between Flagstaff Road and Boulder Canyon via Chapman Drive. It is recommended that the road surface be improved and the adjacent fuels brushed back, to allow larger all-wheel drive fire apparatus. This should be a joint effort between the City of Boulder, Rocky Mountain Fire, and the Four Mile Fire District so that the project may be implemented and completed in a timely manner.
- **The Boulder Rural FPD CWPP.**
  - **Spring Valley Subdivision.** Individual home defensible space was recommended.
  - **Seven Hills Subdivision.** A number of projects tie into the OSMP Anemone Hill project.
  - **Knollwood Fuelbreak.** A fuelbreak project runs along the western edge of the Knollwood subdivision from Sunshine Canyon Drive to Pearl Street.
- **Flagstaff Road treatment.** As of this writing, this project is being implemented by OSMP. The project will have a direct effect on access to and from the upper Flagstaff area. A continuation of this project has been suggested within the draft Rocky Mountain Fire CWPP.

**Note:** Numerous fuel reduction projects exist within the City of Boulder Forest Ecosystem Management Plan written in June of 1999. It is suggested that these be referenced, updated, and implemented. As mentioned above a number of City projects will benefit multiple agencies.

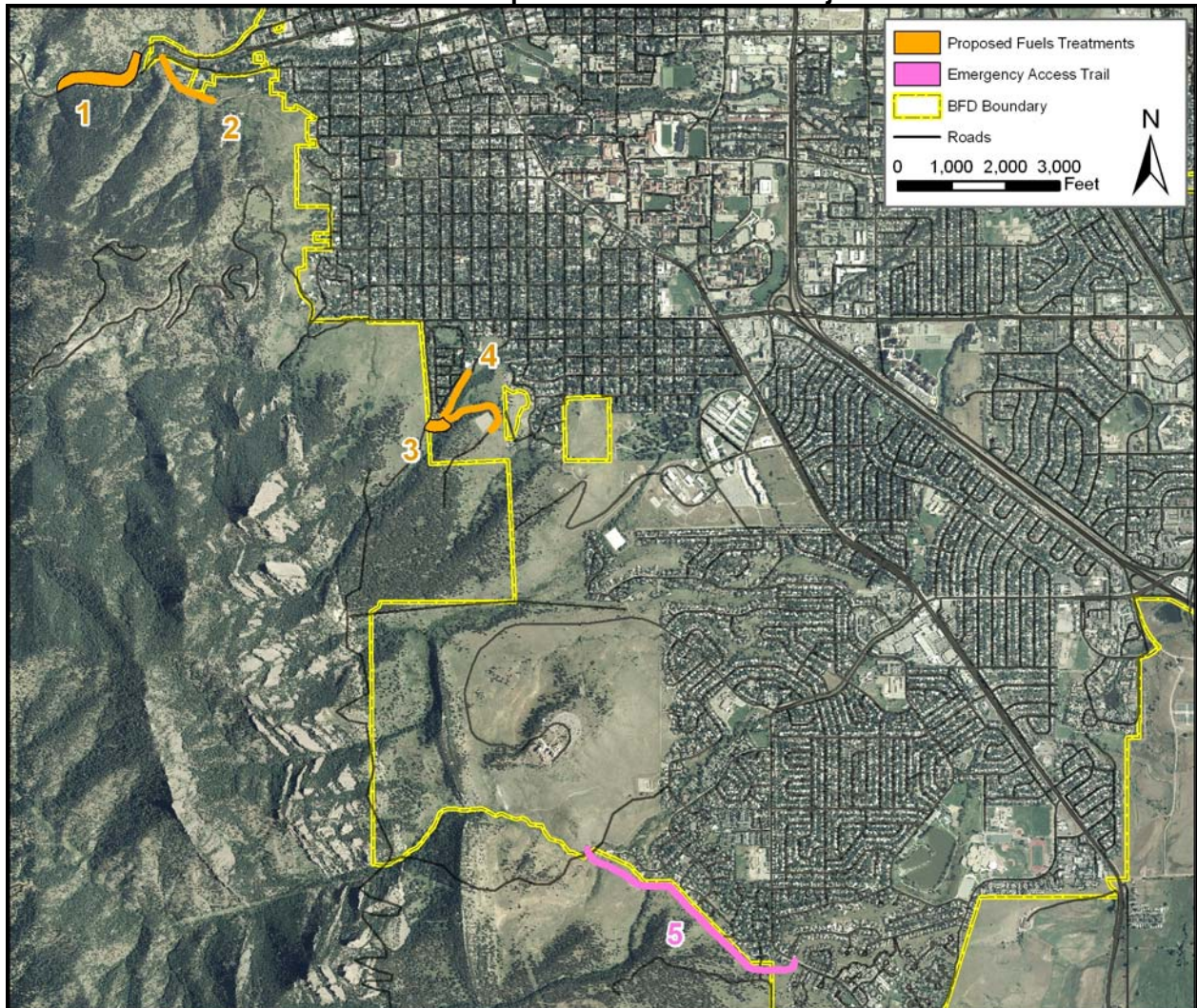
**FIGURE 22. Current and Proposed Projects near City of Boulder**



## Proposed Fuels Reduction Projects for the City of Boulder

The following recommendations are in addition to, not in place of, the fuels reductions mentioned in the **Safety Zones, Addressing, Access, and Evacuation Routes FMUs**. Please note that the boundaries shown on the maps in this document are only approximate. Exact boundaries will be determined when treatment agreements are negotiated with the involved land owners and/or land managers.

**FIGURE 23. Proposed Fuel Reduction Projects**



1. Canon Park Fuelbreak
2. Arapahoe Avenue Fuelbreak
3. Upper Chautauqua Fuelbreak
4. Chautauqua Reservoir Road Treatment
5. Lehigh Street to Bear Creek Emergency Access Trail Treatment

## RECOMMENDATIONS:

---

- 1. Chautauqua Reservoir Road Treatment. Priority level – High (see Figure 22).** This project focuses on limbing and thinning along the Chautauqua Reservoir Road from the access gate up to the reservoir. Thinning should be conducted to conform to the shaded fuelbreak guidelines described in the “Access Route Fuels Modification Recommendations” section. Extra depth should be considered below the road in the drainage (200 feet). This project will help to protect the homes on Goldenrod Drive and the homes between the reservoir and Bellevue Drive (Chautauqua rated as high hazard and Kohler Area rated as very high hazard). This project will be re-enforced by the OSMP fuel reduction projects that have been completed or are slated for completion.
- 2. Upper Chautauqua Fuel Break. Priority Level – High (see Figure 22).** This project is designed to break up the fuel continuity between the Mesa Trail and the Chautauqua Reservoir Road. The boundaries of the fuelbreak should be a minimum of 25 feet in width. Thinning should be conducted so that 10-foot crown spacing is achieved. This fuel break could also serve as firefighter access. Chautauqua rated as high hazard.
- 3. Arapahoe Avenue Fuel Break. Priority Level – High (see Figure 22).** This project focuses on providing a fuelbreak between 200 and 300 Arapahoe Avenues. The project begins at the western perimeter of the Foot of the Mountain Motel and extends to the eastern perimeter of the (proposed) extended defensible of 300 Arapahoe Avenue. Thinning should be conducted to conform to the shaded fuelbreak guidelines described in the “Access Route Fuels Modification Recommendations” section. This treatment will also help to protect the Flagstaff Amphitheatre area from possible Arapahoe Avenue ignitions. The Upper University/Boulder Canyon Area rated as a very high hazard.
- 4. Canon Park Fuel Break. Priority Level – High (see Figure 22).** A fuelbreak using the Boulder Canyon aqueduct above Canon Park should be implemented. The project would use the aqueduct for the majority of the fuel break. The western section of fuel break will tie into Boulder Creek above the homes on Canon Park. The eastern section will tie into Canyon Boulevard below the structure located around 100 Canyon Boulevard. Thinning should be conducted to conform to the shaded fuelbreak guidelines described in the *Access Route Fuels Modification Recommendations* section. The Upper University/Boulder Canyon Area rated as a very high hazard.
- 5. OSMP Projects. Priority Level – High (not shown in graphic form).** Fuel reduction projects exist within the City of Boulder Forest Ecosystem Management Plan written in June of 1999. It is suggested that these be referenced, updated, and implemented.

## Water Supply FMU

---

Within the study area, as in many of the areas of Colorado's Front Range, water is a critical fire suppression issue. The City of Boulder is serviced by an above-average hydrant network. Minor recommendations are found in **Appendix B** having to do with hydrant visibility.

## Areas of Special Interest

### Introduction

In addition to residential communities, certain other properties have been identified by stakeholders to be of special concern or interest. In some cases these areas are departments within the city and present special problems for firefighters. A brief description of each of these properties is presented in this section, followed by recommendations, where applicable, designed to address concerns specific to the individual property. These recommendations are in addition to, not in place of, other recommendations in this report concerning the community or area where these properties are located.

### City of Boulder; Watershed (Silver Lake and Barker Reservoir)

Like most western communities, Boulder depends on stored water most of the year. High streamflows from melting snowpack occur for only a few spring and summer months. Natural streamflows in late summer and the winter are not sufficient to meet customer demands and must be supplemented with previously stored water supplies. The amount of water available also changes from year to year depending on how much snow falls in the mountains. Therefore, Boulder must store water in reservoirs during wetter years to carry over for use in dry years. The City owns seven reservoirs and several natural lakes in the headwaters of the North Boulder Creek basin within the Silver Lake Watershed. In addition, the city owns Boulder Reservoir northeast of Boulder and the Barker Reservoir facilities on Middle Boulder Creek.

There are several reservoirs and natural lakes within the city-owned Silver Lake Watershed at the headwaters of North Boulder Creek just below the continental divide. Barker Reservoir is an 11,700 acre-foot reservoir near Nederland.<sup>[1]</sup>

A wildfire could have a very serious impact on the water quality and infrastructure of these watersheds. Immediate concerns would be erosion, sedimentation and water contamination. Long term issues would be increased run off, soil retention, water quality, and loss of snowpack from exposure. There would be a significant fiscal impact as well. For further analysis see **APPENDIX F**.

## RECOMMENDATIONS

---

- All buildings and improvements adjacent to wildland fuels should follow the recommendations as outlined within the Homes Mitigation FMU and Plain Communities FMU and Appendix B.
- Roadways need to be cleared and maintained to allow for emergency apparatus response.

---

[1] Utilities Division, personal communication; referenced 08-21-07

- Proper signage should be maintained and improved for more effective emergency response.
- Inspections and maintenance should continue on all infrastructure related to the watershed.
- Thinning projects need to be considered for some of the dense canopy forests on barker reservoir and other portions of the Silver Lake watershed.
- A more in-depth study on the adverse impacts of wildfire on the watershed should be completed.

### **City of Boulder Open Space and Mountain Parks**

Over 43,000 acres of city open space land is located in and around the city of Boulder. Some of the land is in agricultural production, while the vast majority of the lands are open to passive recreational uses, including an extensive trail system available for hikers and horseback riders. Bicyclists enjoy riding on designated trails. Picnicking and fishing areas can also be found.<sup>15</sup> With annual visitation of 5.3 million per year, human-caused wildfire ignitions are a legitimate concern.

### **RECOMMENDATIONS:**

---

- Mow grass and weeds to a low height. This should be a minimum of 5 feet from the edge of the trail along both sides.
- All buildings and improvements adjacent to wildland fuels should follow the recommendations as outlined within the Homes Mitigation FMU and Plain Communities FMU and Appendix B.
- Additional fuel reduction projects should be pursued as mentioned in the Fuel Modification Projects FMU. Completed projects will need to be maintained and inspected annually.
- The public should be provided with wildfire educational materials available at all the information kiosks located on Open Space properties.
- Fire danger signage should also be posted at the kiosks. The fire danger for the day should be displayed; this information will need to be kept current.
- The area adjacent to Kossler Lake has had fuel reduction work. This area needs to be evaluated annually and maintained.

---

<sup>15</sup> [http://www.bouldercolorado.gov/index.php?option=com\\_content&task=view&id=1167&Itemid=1082](http://www.bouldercolorado.gov/index.php?option=com_content&task=view&id=1167&Itemid=1082)



## National Center for Atmospheric Research (NCAR)

NCAR provides the university research and teaching community with tools such as aircraft and radar to observe the atmosphere and with the technology and assistance to interpret and use these observations, including supercomputer access, computer models, and user support. NCAR and university scientists work together on research topics in atmospheric chemistry, climate, cloud physics and storms, weather hazards to aviation, and interactions between the sun and earth. In all of these areas, scientists are looking closely at the role of humans in both creating climate change and responding to severe weather occurrences.<sup>16</sup>

### RECOMMENDATIONS:

---

- Continue to implement recommendations outlined in the *UCAR Ecosystem Management Plan*, Anchor Point 2005
- All buildings and improvements (including equipment stored outside) adjacent to wildland fuels should follow the recommendations outlined in the *Homes Mitigation FMU* and **Appendix B**.
- Employees should attend a basic wildfire awareness class provided by the City of Boulder (this could be incorporated into the “all-hazard” preplan mentioned below). This will also serve to educate the employees as to the procedures to follow in the event of a wildfire.
- The City of Boulder should assist NCAR with the creation of an “all-hazard” preplan, which includes wildland fire.

## NIST Boulder Laboratories

The National Institute of Standards and Technology is a federal technology agency whose mission is to promote U.S. innovation and industrial competitiveness by advancing measurement science, standards, and technology in ways that enhance economic security and improve our quality of life.

### RECOMMENDATIONS:

---

- All buildings and improvements (including equipment stored outside) adjacent to wildland fuels should follow the recommendations outlined in the *Homes Mitigation FMU* and **Appendix B**.
- Employees should attend a basic wildfire awareness class provided by the City of Boulder (this could be incorporated into the “all-hazard” preplan mentioned below). This will also serve to educate the employees as to the procedures to follow in the event of a wildfire.
- The City of Boulder should assist NCAR with the creation of an “all-hazard” preplan, which includes wildland fire.

---

<sup>16</sup> <http://www.ncar.ucar.edu/organization/about/>; referenced 08-21-07

## GLOSSARY

---

The following definitions apply to terms used in the City of Boulder Community Wildfire Protection Plan.

**1 hour Timelag fuels:** Grasses, litter and duff; <1/4 inch in diameter.

**10 hour Timelag fuels:** Twigs and small stems; ¼ inch to 1 inch in diameter.

**100 hour Timelag fuels:** Branches; 1 to 3 inches in diameter.

**1000 hour Timelag fuels:** Large stems and branches; >3 inches in diameter.

**Active Crown Fire:** A crown fire in which the entire fuel complex – all fuel strata – become involved, but the crowning phase remains dependent on heat released from the surface fuel strata for continued spread (also called a Running Crown Fire or Continuous Crown Fire).

**ArcGIS 9.x:** Geographic Information System (GIS) software designed to handle mapping data in a way that can be analyzed, queried, and displayed. ArcGIS is in its ninth major revision and is published by the Environmental Systems Research Institute (ESRI).

**Crown Fire (Crowning):** The movement of fire through the crowns of trees or shrubs, which may or may not be independent of the surface fire.

**Defensible Space:** An area around a structure where fuels and vegetation are modified, cleared, or reduced to slow the spread of wildfire toward or from the structure. The design and distance of the defensible space is based on fuels, topography, and the design/materials used in the construction of the structure.

**Energy Release Component:** An index of how hot a fire could burn. ERC is directly related to the 24-hour, potential worst case, total available energy within the flaming front at the head of a fire.

**Extended Defensible Space** (also known as Zone 3): A defensible space area where treatment is continued beyond the minimum boundary. This zone focuses on forest management with fuels reduction being a secondary consideration.

**Fine Fuels:** Fuels that are less than ¼ inch in diameter such as grass, leaves, draped pine needles, fern, tree moss, and some kinds of slash which, when dry, ignite readily and are consumed rapidly.

**Fire Behavior Potential:** The expected severity of a wildland fire expressed as the rate of spread, the level of crown fire activity, and flame length. Fire Behavior Potential is derived from fire behavior modeling programs using the following inputs: fuels, canopy cover, historical weather averages, elevation, slope, and aspect.

**Fire Danger:** Not used as a technical term in this document due to various and nebulous meanings that have been historically applied.

**Fire Hazard:** Given an ignition, the likelihood and severity of Fire Outcomes (Fire Effects) that result in damage to people, property, and/or the environment. Fire Hazard is derived from the Community Assessment and the Fire Behavior Potential.

**Fire Mitigation:** Any action designed to decrease the likelihood of an ignition, reduce Fire Behavior Potential, or to protect property from the impact of undesirable Fire Outcomes.

**Fire Outcomes (aka Fire Effects):** A description of the expected effects of a wildfire on people, property, and/or the environment based on the Fire Behavior Potential and physical presence of Values at Risk. Outcomes can be desirable as well as undesirable.

**Fire Risk:** The probability that an ignition will occur in an area with potential for damaging effects to people, property, and/or the environment. Risk is based primarily on historical ignitions data.

**Flagged Addressing:** A term describing the placement of multiple addresses on a single sign, servicing multiple structures located on a common access.

**FlamMap:** A software package created by the Joint Fire Sciences Program, Rocky Mountain Research Station. The software uses mapped environmental data such as Elevation, Aspect, Slope, and Fuel Model, along with fuel moisture and wind information, to generate predicted fire behavior characteristics such as Flame Length, Crown Fire Activity, and Spread Rate.

**Flame Length:** The distance between the flame tip and the midpoint of the flame depth at the base of the flame (generally the ground surface) – an indicator of fire intensity.

**FMU (Fire Management Unit):** A method of prioritizing fire mitigation work efforts. Units can be defined by function (e.g., public education efforts) or geography (e.g., fuel reduction projects in a given area).

**Fuelbreak:** A natural or constructed discontinuity in a fuel profile used to isolate, stop, or reduce the spread of fire. Fuelbreaks may also make retardant lines more effective and serve as control lines for fire suppression actions. Fuel breaks in the WUI are designed to limit the spread and intensity of crown fire activity.

**ICP (Incident Command Post):** The base camp and command center from which fire suppression operations are directed.

**ISO (Insurance Standards Office):** A leading source of risk information to insurance companies. ISO provides fire risk information in the form of ratings used by insurance companies to price fire insurance products to property owners.

**Jackpot Fuels:** a large concentration of discontinuous fuels in a given area such as a slash pile.

**Passive Crown Fire:** a crown fire in which individual or small groups of trees torch out (candle), but solid flaming in the canopy fuels cannot be maintained except for short periods.

**Slash:** Debris left after logging, pruning, thinning, or brush cutting; includes logs, chips, bark, branches, stumps, and broken understory trees or brush.

**Spotting:** Behavior of a fire producing sparks or embers that are carried by the wind and start new fires beyond the zone of direct ignition by the main fire.

**Structural Triage:** The process of identifying, sorting, and committing resources to a specific structure.

**Surface Fire:** A fire that burns on the surface litter, debris, and small vegetation on the ground.

**Timelag:** Time needed under specified conditions for a fuel particle to lose 63 percent of the difference between its initial moisture content and its equilibrium moisture content.

**Values at Risk:** People, property, ecological elements, and other human and intrinsic values within the project area. Values at Risk are identified by inhabitants as important to the way of life of the study area and are specifically susceptible to damage from undesirable fire outcomes.

**WHR (Community Wildfire Hazard Rating. AKA Community Assessment):** A fifty-point scale analysis designed to identify factors which increase the potential for and/or severity of undesirable fire outcomes in WUI communities.

**WUI (Wildland Urban Interface):** The line, area, or zone where structures and other human development meet or intermingle with undeveloped wildland or vegetative fuels. Sometimes referred to as Urban Wildland Interface, or UWI.

# CITY OF BOULDER CWPP

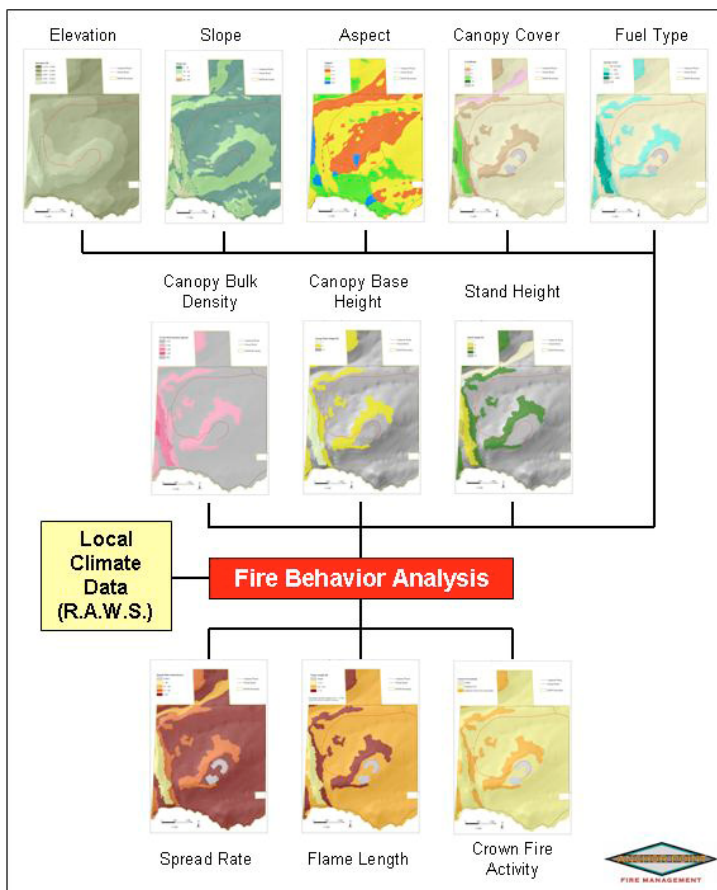
## APPENDIX A

### FIRE BEHAVIOR POTENTIAL ANALYSIS METHODOLOGY

#### Purpose

The purpose of this document is to describe the methodology used to evaluate the threat represented by physical hazards such as fuels, weather and topography to Values at Risk in the study area, by modeling their effects on fire behavior potential.

FIGURE 1. Flow Chart



**Note: these graphics are descriptive only and are not specific to this project.**

The fire behavior potential analysis reports graphically the probable range of spread rate, flame length, and crown fire potential for the analysis area, based upon a set of inputs significant to fire behavior. The model inputs include aspect, slope, elevation, canopy cover, fuel type, canopy bulk density, canopy base height, stand height, and climate data.

The model outputs are determined using FlamMap<sup>1</sup>, which combines surface fire predictions with the potential for crown fire development. Calculations for surface fire predictions (rate of spread and flame length) are based on the USDA Forest Service's BEHAVE<sup>2</sup> model.

The BEHAVE fire behavior prediction and fuel modeling system was employed to determine surface fire behavior estimates for this study. BEHAVE is a nationally recognized set of calculations used to estimate a surface fire's intensity and rate of spread given certain conditions of topography, fuels, and weather.

The BEHAVE modeling system has been used for a variety of applications, including prediction of an ongoing fire, prescribed fire planning, fuel hazard assessment, initial attack dispatch, and fire prevention planning and training. Predictions of wildland fire behavior are made for a single point in time and space, given simple user-defined fuels, weather, and topography. Requested values depend on the modeling choices made by the user.

#### Assumptions of BEHAVE:

- Fire is predicted at the flaming front
- Fire is free burning
- Behavior is heavily weighted towards the fine fuels
- Fuels are continuous and uniform
- Fires are considered to be surface fires

#### **FlamMap**

Anchor Point uses FlamMap to evaluate the potential fire conditions in the fire behavior study area. The City of Boulder encompasses 16,282 acres (25 square miles). The study area for the fire behavior analysis covers approximately 31,730 acres (49.5 square miles). This area includes the Fire Department response area and a half-mile buffer in all directions. The use of this buffer provides the district with an analysis of potential fire behavior on adjacent lands. From both a planning and tactical perspective, it is important to evaluate exposures beyond the jurisdiction. The study area is broken down into grid cells of 10-meters per side (10M). Using existing vector and raster spatial data and field data, ArcGIS spatial analysis capabilities are used to calculate model inputs for each 10M cell. These values are input into FlamMap, along with reference weather and fuel moisture (long-term weather observations statistically calculated from the Sugarloaf Remote Automated Weather Station information). The outputs of FlamMap include the estimated Rate of Spread (ROS) (from BEHAVE), Flame Length (FL) (from BEHAVE) and Crown Fire Activity for a fire in that 10M cell. The model computes these

---

<sup>1</sup> Mark Finney, Stuart Brittain and Rob Seli., The Joint Fire Sciences Program of the Rocky Mountain Research Station (USDA Forest Service, Missoula, Montana), the Bureau of Land Management and Systems for Environmental Management (Missoula, Montana).

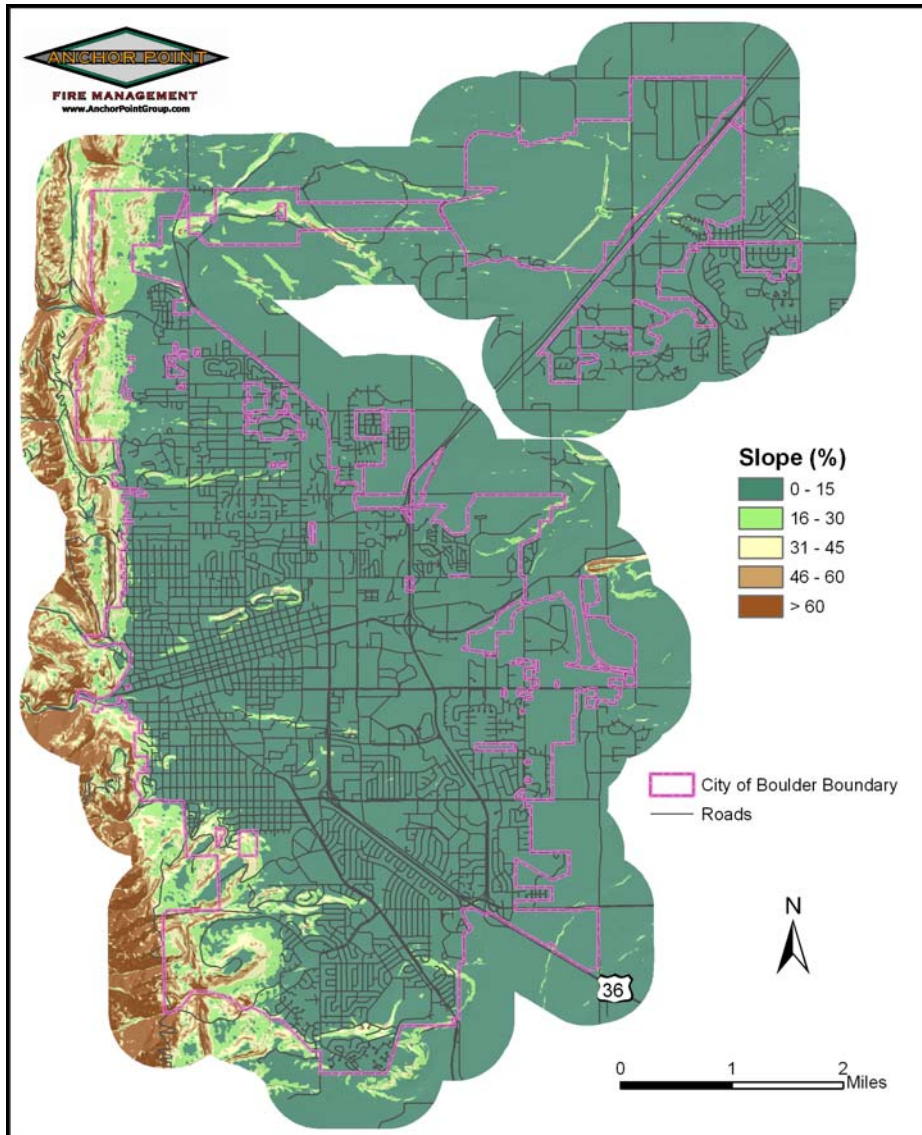
<sup>2</sup> Patricia L. Andrews, producer and designer, Collin D. Bevins, programmer and designer, The Joint Fire Sciences Program of the Rocky Mountain Research Station (USDA Forest Service, Missoula, Montana) and Systems for Environmental Management (Missoula, Montana).

values for each cell in the study area independently, so the data in each cell is unaffected by adjacent cells.

### Fire Behavior Inputs

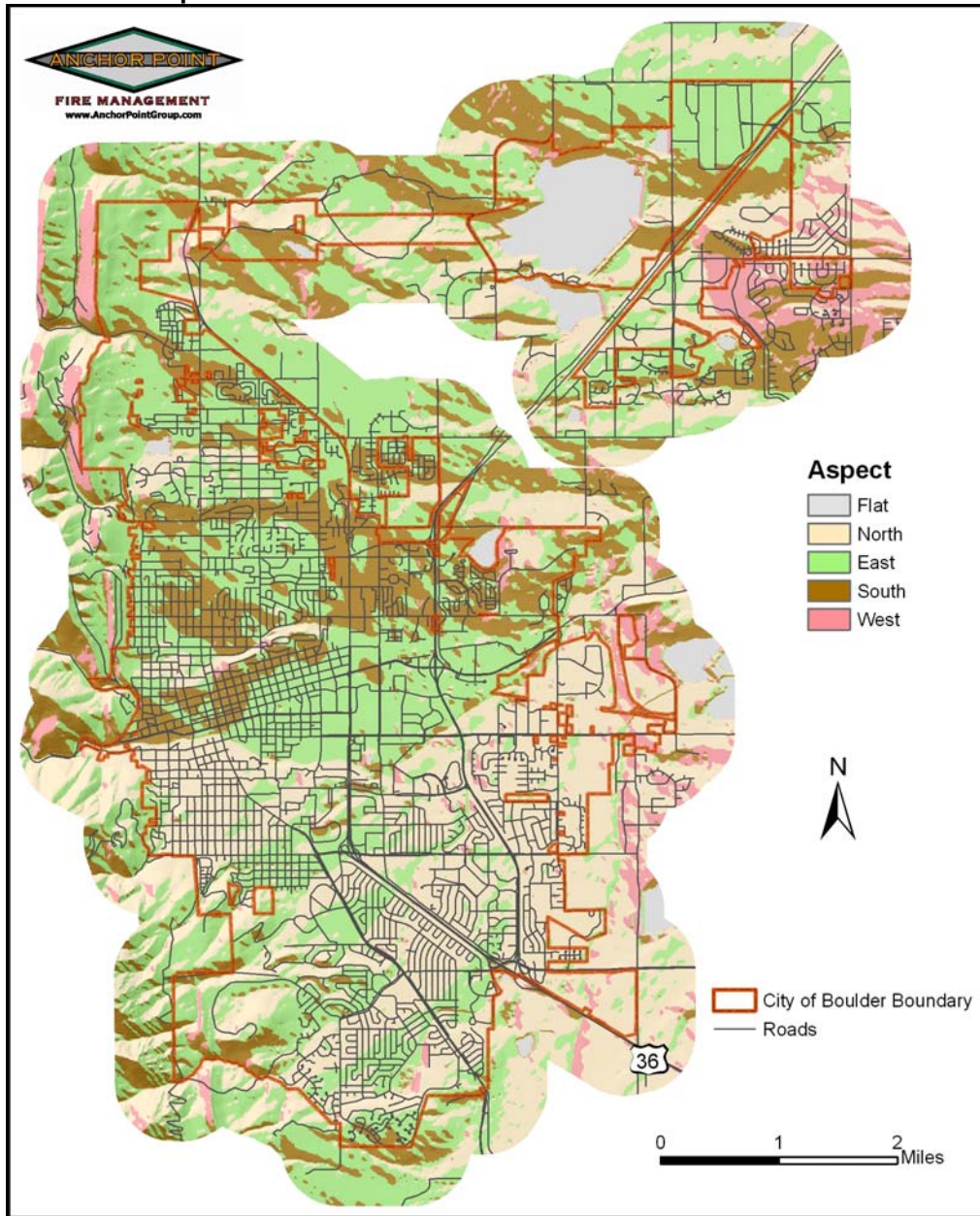
The major factors influencing fire behavior are fuels (type and coverage), weather, and topography (aspect, slope and elevation). The following pages contain a brief explanation of each.

**FIGURE 2. Percent Slope**



Slopes are shown here as percent (rise/run x100). Steeper slopes intensify fire behavior and thus will contribute to a higher wildfire hazard rating. Rates of spread for a slope of 30% are typically double those of flat terrain, when all other influences are equal.

**FIGURE 3. Aspect**

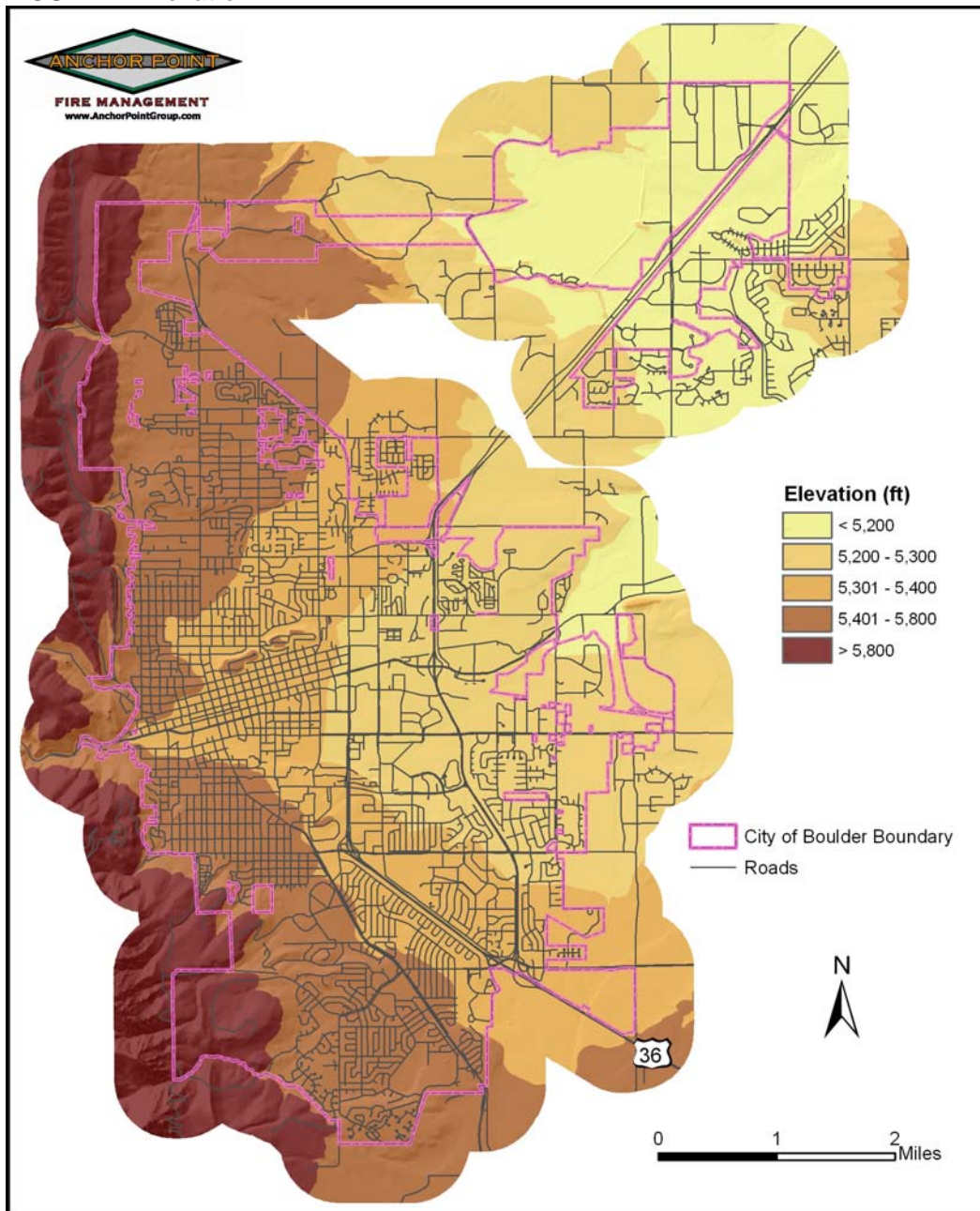


Aspects are shown as degrees from north ranging from 0 to 360 according to their orientation. Aspects are influential in the type and quantity of vegetative fuels. Fuels on south facing slopes tend to be drier and more lightly loaded than fuels on north facing slopes, when all other influences are equal. Aspect also has an influence on plant species dominance.

Classification	North	East	South	West
Range	315-45	45-135	135-225	225-315



FIGURE 4. Elevation



Elevations within the study area range from 5,000' to over 5,800'. As elevation increases, environmental conditions, fuel species, and characteristics change.

## Fuel Models and Fire Behavior

Fire behavior fuel models are a set of numbers that describe fuels in terms that a fire behavior model, in this case **FlamMap**, can use. There are seven characteristics used to categorize fuel models.

- Fuel Loading
- Size and Shape
- Compactness
- Horizontal Continuity
- Vertical Arrangement
- Moisture Content
- Chemical Content

Each of the major fuel types present in the study area is described below in terms of the characteristics that coincide with that fuel model. Unless otherwise noted, fuel model descriptions are taken from Anderson's *Aids to Determining Fuel Models for Estimating Fire Behavior*<sup>3</sup>, a national standard guide to fuel modeling.

***Vegetation for the project area may or may not be specifically listed in the description.***

Plant species are only an aid to help visualize the characteristics of the model. The photos are taken from the project area and show where the local vegetation fits in. A table showing a range of surface fire behavior based on the **BEHAVE** system is also included.

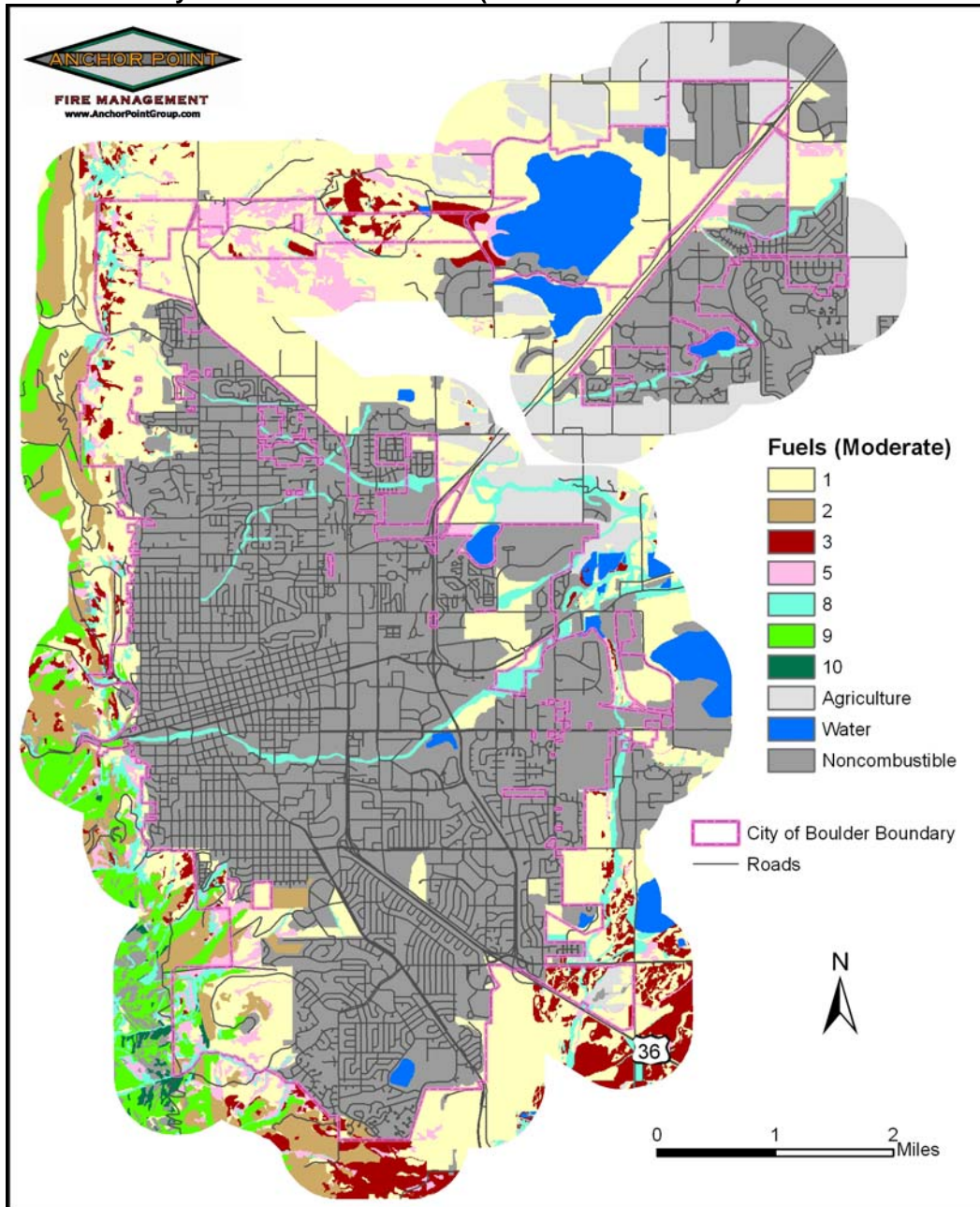
The study area is represented primarily by seven fuel models (FM): FM 1, 2, 3, 5, 8, 9, and 10. Other fuel models may exist, but not in quantities sufficient to significantly influence fire behavior in the Wildland Urban Interface.

The following graphics (**Figures 5 and 6**) represent fuel modeling under both moderate and extreme fire conditions. The primary difference between the two fuel model maps is that Figure 5 shows agriculture land as noncombustible while Figure 6 shows agriculture land as combustible (it is characterized as FM1).

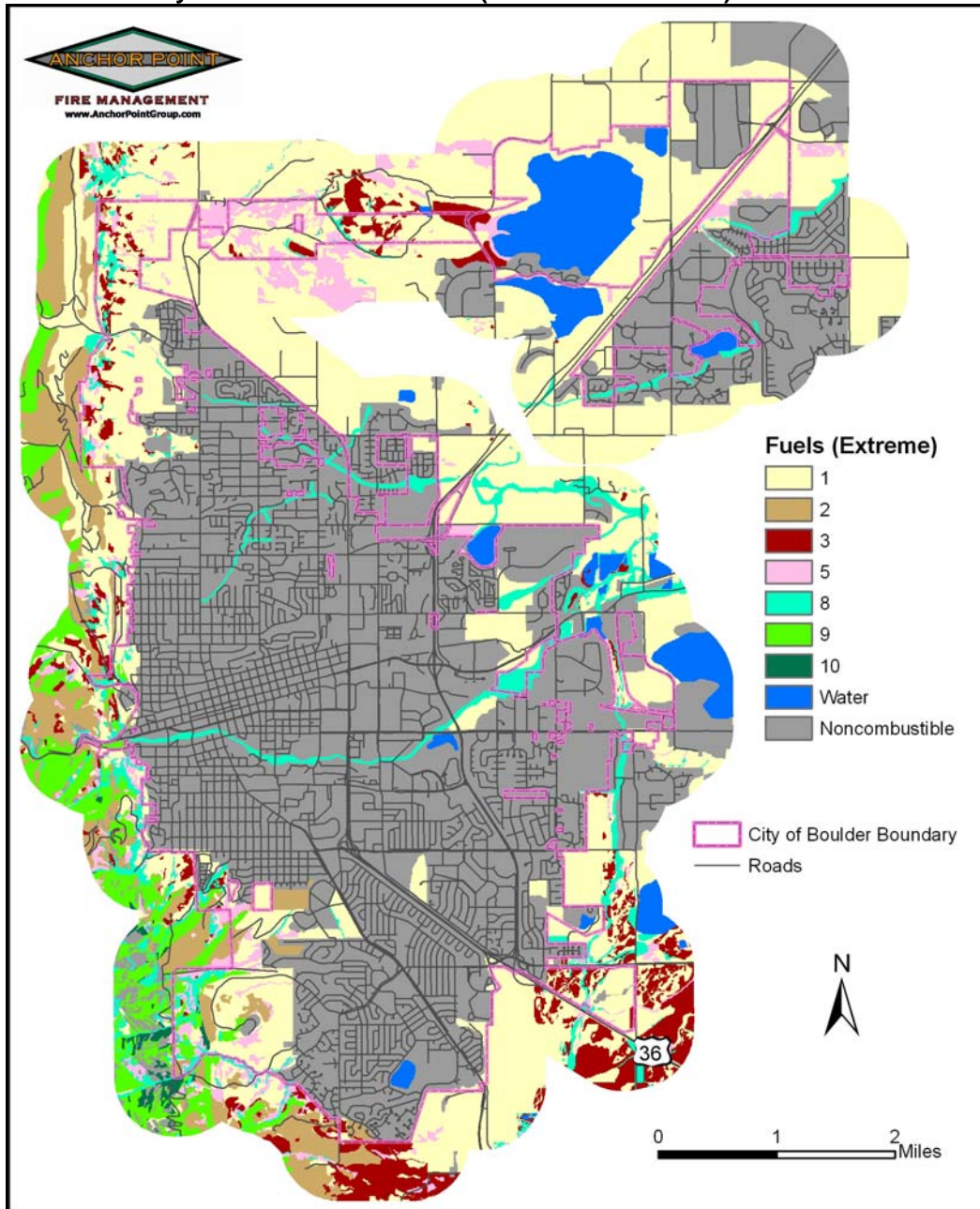
---

<sup>3</sup> Anderson, Hal. 1982. *Aids to Determining Fuel Models for Estimating Fire Behavior*. Gen. Tech. Rep. INT-122. Ogden, UT: U.S. Department of Agriculture, Forest Service, Intermountain Research Station 22 p. (NFES 1574).

**FIGURE 5. City of Boulder Fuel Models (Moderate Conditions)**



**FIGURE 6. City of Boulder Fuel Models (Extreme Conditions)**



Note the absence of the agricultural land fuel model, which indicates that these areas could burn under extreme conditions.

## **FUEL MODEL 1<sup>4</sup>**

**FIGURE 7. Short Grasses**



### **Characteristics**

Grasslands and savanna are represented along with stubble, grass-tundra, and grass-shrub combinations.

### **Common Types/Species**

Annual and perennial grasses are included in this fuel model.

### **Fire Behavior**

Fire spread is governed by the fine, very porous, and continuous herbaceous fuels that have cured or are nearly cured. Fires in this fuel model are surface fires that move rapidly through the cured grass and associated material. Very little shrub or timber is present—generally less than one third of the area.

---

<sup>4</sup> Anderson, Hal. 1982. *Aids to Determining Fuel Models for Estimating Fire Behavior*. Gen. Tech. Rep. INT-122. Ogden, UT: U.S. Department of Agriculture, Forest Service, Intermountain Research Station 22 p. (NFES 1574).

## FUEL MODEL 1

Rate of spread in chains/hour  
(1 chain=66 ft) (80 chains/HR = 1 MPH)

		Mid-flame Wind Speed					
		2.0	4.0	6.0	8.0	10.0	12.0
Fine Dead Fuel moisture %	2.0	28.8	92.9	203.6	362.4	570.1	665.6
	4.0	22.0	71.1	155.7	277.0	345.1	345.1
	6.0	19.4	62.4	136.8	243.4	270.1	270.1
	8.0	16.7	53.9	118.1	198.7	198.7	198.7
	10.0	11.0	35.6	64.8	64.8	64.8	64.8

10-hr fuel = 9%, 100-hr fuel = 11%, herbaceous fuel moisture = 68%, slope = 10%

## Flame Length in Feet

		Mid-flame Wind Speed					
		2.0	4.0	6.0	8.0	10.0	12.0
Fine Dead Fuel moisture %	2.0	3.0	5.1	7.3	9.6	11.8	12.7
	4.0	2.4	4.1	5.9	7.8	8.6	8.6
	6.0	2.2	3.8	5.5	7.1	7.5	7.5
	8.0	2.0	3.4	4.9	6.3	6.3	6.3
	10.0	1.4	2.4	3.2	3.2	3.2	3.2

## **FUEL MODEL 2<sup>5</sup>**

**FIGURE 8. Open canopy shrubs with grass understory**



### **Characteristics**

Fire spread is primarily through the fine herbaceous fuels, either curing or dead.

### **Common Types/Species**

Open shrub lands and pine stands or scrub oak stands that cover one third to two thirds of the area may generally fit this model. Such stands may include clumps of fuels that generate higher intensities and that may produce firebrands. Some piñon-juniper may be in this model.

### **Fire Behavior**

These are surface fires where the herbaceous material—in addition to litter and dead-down stemwood from the open shrub or timber overstory—contributes to the fire intensity.

---

<sup>5</sup> Anderson, Hal. 1982. *Aids to Determining Fuel Models for Estimating Fire Behavior*. Gen. Tech. Rep. INT-122. Ogden, UT: U.S. Department of Agriculture, Forest Service, Intermountain Research Station 22 p. (NFES 1574).

## FUEL MODEL 2

Rate of spread in chains/hour  
(1 chain=66 ft) (80 chains/HR = 1 MPH)

		Mid-flame Wind Speed					
		2.0	4.0	6.0	8.0	10.0	12.0
Fine Dead Fuel moisture %		2.0	4.0	6.0	8.0	10.0	12.0
	2.0	13.8	37.9	75.0	123.9	184.3	255.6
	4.0	11.3	31.1	61.5	101.7	151.2	209.7
	6.0	10.0	27.7	54.7	90.4	134.4	186.4
	8.0	9.2	25.4	50.3	83.1	123.6	171.4
	10.0	8.2	22.7	44.8	74.1	110.2	152.8
	12.0	6.5	17.9	35.3	58.3	86.7	120.3

10-hr fuel 9%, 100= 11%, herbaceous fuel moisture = 68%, slope 10%

## Flame Length in Feet

		Mid-flame Wind Speed					
		2.0	4.0	6.0	8.0	10.0	12.0
Fine Dead Fuel moisture %		2.0	4.0	6.0	8.0	10.0	12.0
	2.0	4.5	7.2	9.9	12.4	14.9	17.3
	4.0	3.9	6.2	8.4	10.6	12.7	14.8
	6.0	3.5	5.7	7.7	9.7	11.7	13.6
	8.0	3.4	5.4	7.3	9.2	11.1	12.9
	10.0	3.1	4.9	6.7	8.5	10.2	11.9
	12.0	2.5	4.0	5.5	7.0	8.4	9.7



## **FUEL MODEL 3<sup>3</sup>**

**FIGURE 9. Tall Grass**



### **Characteristics**

This model consists of tall grass stands. Heights average around three feet, but considerable variation may exist.

### **Common Types/Species**

Wild or cultivated grains that have not been harvested can be considered similar to tall prairie and marshland grasses.

### **Fire Behavior**

Fires in this fuel are the most intense of the grass group and display high rates of spread under the influence of wind. Wind may drive fire into the upper sections of the grass and across standing water. Approximately one-third or more of the stand is considered dead or cured and supports the fire.

---

<sup>3</sup> Anderson, Hal. 1982. *Aids to Determining Fuel Models for Estimating Fire Behavior*. Gen. Tech. Rep. INT-122. Ogden, UT: U.S. Department of Agriculture, Forest Service, Intermountain Research Station 22 p. (NFES 1574).

### FUEL MODEL 3

Rate of spread in chains/hour  
(1 chain=66 ft) (80 chains/HR = 1 MPH)

		Mid-flame Wind Speed					
		2.0	4.0	6.0	8.0	10.0	12.0
Fine Dead Fuel moisture %	2.0	61.7	139.3	230.4	331.6	441.1	557.6
	4.0	48.6	109.7	181.5	261.2	347.4	439.2
	6.0	40.2	90.7	150	215.9	287.1	363
	8.0	34.8	78.6	130	187.1	248.9	314.7
	10.0	31.4	70.8	117.2	168.7	224.4	283.6
	12.0	29	65.3	108.1	155.6	207	261.6

10-hr fuel 9%, 100= 11%, herbaceous fuel moisture = 68%, slope 10%

### Flame Length in Feet

		Mid-flame Wind Speed					
		2.0	4.0	6.0	8.0	10.0	12.0
Fine Dead Fuel moisture %	2.0	11.3	16.5	20.7	24.5	28	31.2
	4.0	9.4	13.7	17.3	20.4	23.3	25.9
	6.0	8.2	11.9	15	17.7	20.2	22.5
	8.0	7.4	10.8	13.6	16	18.3	20.4
	10.0	6.9	10.1	12.7	15	17.1	19.1
	12.0	6.6	9.6	12.1	14.3	16.3	18.2

## **FUEL MODEL 5<sup>6</sup>**

**FIGURE 10. Brush**



### **Characteristics**

This model consists of continuous stands of low brush. Generally, heights do not exceed six feet. The stands will have a grass or scattered grass understory. Usually shrubs are short and almost totally cover the area.

### **Common Types/Species**

Young, green stands with minimal dead wood would qualify: laurel, vine maple, alder, or even chaparral, manzanita, or chamise. Mountain grasses are also associated with this type.

### **Fire Behavior**

The fires are generally not very intense because surface fuel loads are light, the shrubs are young with little dead material, and the foliage contains little volatile material. Fire is generally carried in the surface fuels that are made up of litter cast by the shrubs and the grasses or forbs in the understory. Cured leaves retained on shrubs can cause greater intensities.

---

<sup>6</sup> Anderson, Hal. 1982. *Aids to Determining Fuel Models for Estimating Fire Behavior*. Gen. Tech. Rep. INT-122. Ogden, UT: U.S. Department of Agriculture, Forest Service, Intermountain Research Station 22 p. (NFES 1574).

## FUEL MODEL 5

Rate of spread in chains/hour  
(1 chain=66 ft) (80 chains/HR = 1 MPH)

		Mid-flame Wind Speed					
		2.0	4.0	6.0	8.0	10.0	12.0
Fine Dead Fuel moisture %		2.0	4.0	6.0	8.0	10.0	12.0
	2.0	8.7	20.2	34.3	50.5	68.3	87.6
	4.0	7.4	17.2	29.3	43.1	58.3	74.7
	6.0	5.6	12.9	21.9	32.3	43.6	56
	8.0	2.6	6.1	10.4	15.3	20.7	21.7
	10.0	2.6	5.9	10.1	14.8	20.1	20.3
	12.0	2.5	5.7	9.7	14.3	18.7	18.7

10-hr fuel 9%, 100 = 11%, herbaceous fuel moisture = 68%, slope 10%

## Flame Length in Feet

		Mid-flame Wind Speed					
		2.0	4.0	6.0	8.0	10.0	12.0
Fine Dead Fuel moisture %		2.0	4.0	6.0	8.0	10.0	12.0
	2.0	4	6	7.6	9.1	10.4	11.7
	4.0	3.5	5.2	6.6	7.9	9.1	10.2
	6.0	2.7	4	5.1	6.1	7	7.8
	8.0	1.4	2	2.6	3.1	3.5	3.6
	10.0	1.3	2	2.5	3	3.4	3.5
	12.0	1.3	1.9	2.4	2.9	3.3	3.3

## **FUEL MODEL 8<sup>3</sup>**

**FIGURE 11. Timber Litter, Light Fuel Load**



### **Characteristics**

This fuel model is represented by closed canopy stands of hardwoods, Lodgepole pine, or Ponderosa pine with little under growth. Hardwoods that have leafed out support fire in the compact litter layer. Amounts of needle and woody litter are also low.

### **Common Types/Species**

This fuel model is most often represented by Lodgepole pine but Ponderosa pine can be included. Hardwood species would include Cottonwoods and Willows. There are little or no understory plants.

### **Fire Behavior**

Fires in this fuel model are slow burning, low intensity fires burning in surface fuels. Fuels are mainly needles and woody litter. Heavier fuel loadings can cause flare-ups. Heavier fuel loads have the potential to develop crown fires in extreme burning conditions.

---

<sup>3</sup> Anderson, Hal. 1982. *Aids to Determining Fuel Models for Estimating Fire Behavior*. Gen. Tech. Rep. INT-122. Ogden, UT: U.S. Department of Agriculture, Forest Service, Intermountain Research Station 22 p. (NFES 1574).

## FUEL MODEL 8

Rate of spread in chains/hour (1 chain=66 ft)

		Mid-flame Wind Speed					
		2.0	4.0	6.0	8.0	10.0	12.0
Fine Dead Fuel moisture %		2.0	4.0	6.0	8.0	10.0	12.0
	2.0	1.1	2.3	3.8	5.6	7.7	9.7
	4.0	0.9	1.8	3.1	4.6	6.2	6.6
	6.0	0.7	1.5	2.6	3.8	4.8	4.8
	8.0	0.6	1.3	2.3	3.3	3.7	3.7
	10.0	0.6	1.2	2.0	3.0	3.1	3.1
	12.0	0.5	1.1	1.8	2.7	2.7	2.7

10 hr fuel=9, 100 hr fuel=11 herbaceous fuel moisture=68 slope=10%

Flame Length in Feet

		Mid-flame Wind Speed					
		2.0	4.0	6.0	8.0	10.0	12.0
Fine Dead Fuel moisture %		2.0	4.0	6.0	8.0	10.0	12.0
	2.0	0.9	1.3	1.6	2.0	2.3	2.5
	4.0	0.8	1.1	1.4	1.7	1.9	2.0
	6.0	0.7	1.0	1.2	1.5	1.6	1.6
	8.0	0.6	0.9	1.1	1.3	1.4	1.4
	10.0	0.6	0.8	1.0	1.2	1.3	1.3
	12.0	0.5	0.8	1.0	1.2	1.2	1.2

## **FUEL MODEL 9<sup>4</sup>**

**FIGURE 12. Timber Litter (note heavier surface fuels)**



### **Characteristics**

Both long-needle conifer stands and hardwood stands, especially the oak-hickory types, are typical. Concentrations of dead-down woody material will contribute to possible torching out of trees, spotting, and crowning.

### **Common Types/Species**

Closed stands of long-needled pine like Ponderosa, Jeffrey, and Red pines, or southern pine plantations are grouped in this fuel model.

### **Fire Behavior**

Fires in this fuel model run through the surface litter faster than model 8 and have longer flame height. Fall fires in hardwoods are predictable, but high winds will actually cause higher rates of spread than predicted because of spotting caused by rolling and blowing leaves.

---

<sup>4</sup> Anderson, Hal. 1982. *Aids to Determining Fuel Models for Estimating Fire Behavior*. Gen. Tech. Rep. INT-122. Ogden, UT: U.S. Department of Agriculture, Forest Service, Intermountain Research Station 22 p. (NFES 1574).

## FUEL MODEL 9

Rate of spread in chains/hour (1 chain=66 ft)

		Mid-flame Wind Speed					
Fine Dead Fuel moisture %		2.0	4.0	6.0	8.0	10.0	12.0
	2.0	4.0	9.7	18.0	28.7	41.4	56.1
	4.0	3.1	7.7	14.2	22.6	32.7	44.3
	6.0	2.6	6.4	11.8	18.7	27.0	36.6
	8.0	2.3	5.5	10.2	16.2	23.5	31.8
	10.0	2.0	5.0	9.2	14.7	21.2	28.7
	12.0	1.9	4.6	8.5	13.5	19.5	26.5

10 hr fuel=9, 100 hr fuel=11%, herbaceous fuel moisture=68%, slope=10%

### Flame Length in Feet

		Mid-flame Wind Speed					
Fine Dead Fuel moisture %		2.0	4.0	6.0	8.0	10.0	12.0
	2.0	2.3	3.5	4.7	5.8	6.8	7.9
	4.0	1.9	2.9	3.9	4.8	5.7	6.5
	6.0	1.7	2.5	3.4	4.2	4.9	5.7
	8.0	1.5	2.3	3.1	3.8	4.5	5.2
	10.0	1.4	2.2	2.9	3.5	4.2	4.8
	12.0	1.4	2.1	2.7	3.4	4.0	4.6



## **Fuel Model 10<sup>5</sup>**

**FIGURE 13. Timber Litter (note heavier fuels and understory)**



### **Characteristics**

This fuel model is represented by dense stands of over-mature Ponderosa pine, Lodgepole pine, mixed conifer and continuous stands of Douglas fir. In all stand types, heavy downed material is present. There is also a large amount of dead-down woody fuels. Reproduction of vegetation may be present, acting as ladder fuels. This fuel model includes stands of budworm-killed Douglas fir, and closed stands of Ponderosa pine with large amounts of ladder and surface fuels. Stands of Lodgepole pine with heavy loadings of downed trees are also present. This fuel model can occur from the foothills through the sub-alpine zone.

### **Common Types/Species**

All types of vegetation can occur in this fuel model, but primary species are Douglas fir, Ponderosa pine and Lodgepole pine.

### **Fire Behavior**

Fire intensities in this fuel model can be moderate to extreme. Fire moves through dead, downed woody material. Torching of trees and spot fires are more frequent. Crown fires are quite possible.

---

<sup>5</sup> Anderson, Hal. 1982. *Aids to Determining Fuel Models for Estimating Fire Behavior*. Gen. Tech. Rep. INT-122. Ogden, UT: U.S. Department of Agriculture, Forest Service, Intermountain Research Station 22 p. (NFES 1574).

## FUEL MODEL 10

Rate of spread in chains/hour (1 chain=66 ft)

		Mid-flame Wind Speed					
Fine Dead Fuel moisture %		2.0	4.0	6.0	8.0	10.0	12.0
	2.0	3.5	7.5	12.6	18.5	25.1	32.2
	4.0	3.1	6.7	11.2	16.4	22.2	28.6
	6.0	2.8	6.1	10.2	14.9	20.2	26
	8.0	2.6	5.7	9.5	13.9	18.8	24.1
	10.0	2.5	5.3	9	13.1	17.8	22.9
	12.0	2.4	5.1	8.6	12.6	17	21.9

10 hr fuel=9%, 100 hr fuel=11%, herbaceous fuel moisture=68%, slope=10%

### Flame Length in Feet

		Mid-flame Wind Speed					
Fine Dead Fuel moisture %		2.0	4.0	6.0	8.0	10.0	12.0
	2.0	3.7	5.2	6.6	7.9	9.1	10.2
	4.0	3.3	4.7	6	7.1	8.2	9.2
	6.0	3.1	4.4	5.5	6.6	7.6	8.5
	8.0	2.9	4.1	5.2	6.2	7.2	8
	10.0	2.8	4	5	6	6.9	7.7
	12.0	2.7	3.8	4.9	5.8	6.7	7.5

**Reference Weather Used in the Fire Behavior Potential Evaluation**

The weather inputs for FlamMap were created by using weather data collected at the Sugarloaf Remote Automated Weather Station (RAWS).

**Sugarloaf Site Information**

Latitude (dd mm ss)	40 ° 01 ' 81 " N
Longitude (dd mm ss)	105 ° 36 ' 14 " W
Elevation (ft.)	6,733

Weather observations from the Sugarloaf RAWS were averaged for a thirty-year period (1977-2006) to calculate these conditions. The moderate conditions class (16<sup>th</sup> to 89<sup>th</sup> percentile) was calculated for each variable (1 hour, 10 hour, and 100 hour fuel moisture, woody fuel moisture, herbaceous fuel moisture, and wind speed) using Fire Family Plus. This weather condition class most closely represents a moderate fire season day.

The extreme conditions class was calculated using 97<sup>th</sup> percentile weather data. In other words, the weather conditions on the four most severe fire weather days (sorted by Spread Component) in each season for the thirty-year period were averaged together. It is reasonable to assume that similar conditions may exist for at least four days of the fire season during an average year. In fact, during extreme years such conditions may exist for significantly longer periods. Even these calculations may be conservative compared to observed fire behavior. The following values were used in **FlamMap**:

Moderate Weather Conditions	
Variable	Value
20 ft Wind speed up slope	10 mph
Herbaceous fuel moisture	68%
Woody fuel moisture	110%
100-hr fuel moisture	11%
10-hr fuel moisture	9%

Extreme Weather Conditions	
Variable	Value
20 ft Wind speed up slope	19 mph
Herbaceous fuel moisture	62%
Woody fuel moisture	99%
100-hr fuel moisture	9%
10-hr fuel moisture	6%

**Note:** Strong winds at 20 ft will feel significantly less noticeable on the skin at ground level. For example, a “gentle breeze” on the skin may constitute an 11 MPH wind at 20 feet, adding one of the components necessary for extreme weather conditions.

### **Dead Fuel Moisture**

Dead fuel moisture responds solely to ambient environmental conditions and is critical in determining fire potential. Dead fuel moistures are classed by timelag. A fuel's timelag is proportional to its diameter and is loosely defined as the time it takes a fuel particle to reach two-thirds of its way to equilibrium with its local environment. Dead fuels in NFDRS fall into four classes: 1, 10, 100, and 1000 hour.

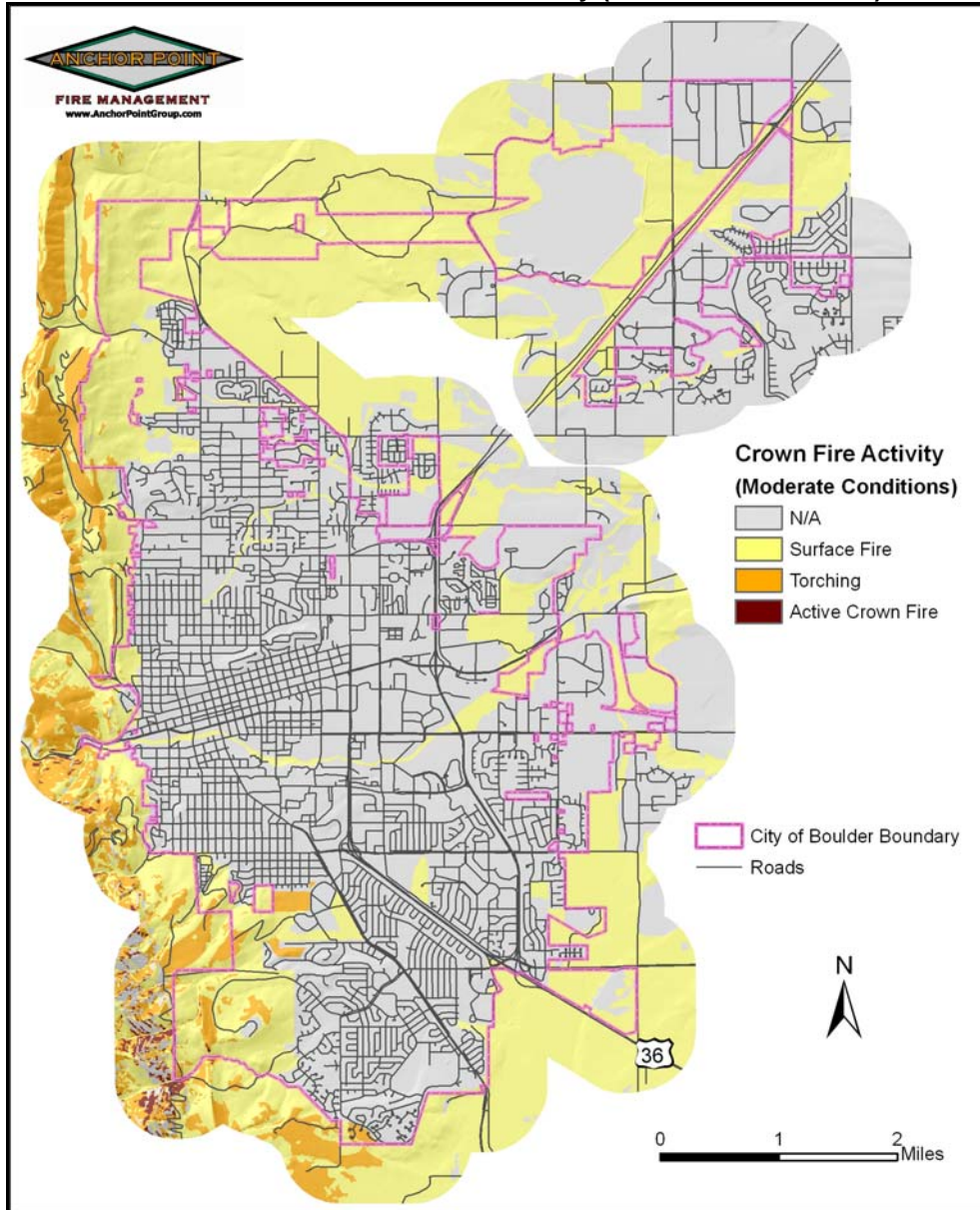
### **Live Fuel Moisture**

Live fuel Moisture is the amount of water in a fuel, expressed as a percent of the oven-dry weight of that fuel. A fuel moisture between 300% and 30% is considered live. Anything below 30% is considered dead fuel. Fuel moistures can exceed 100% because the living cells can expand beyond their normal size to hold more water when available.

## Fire Behavior Analysis Outputs

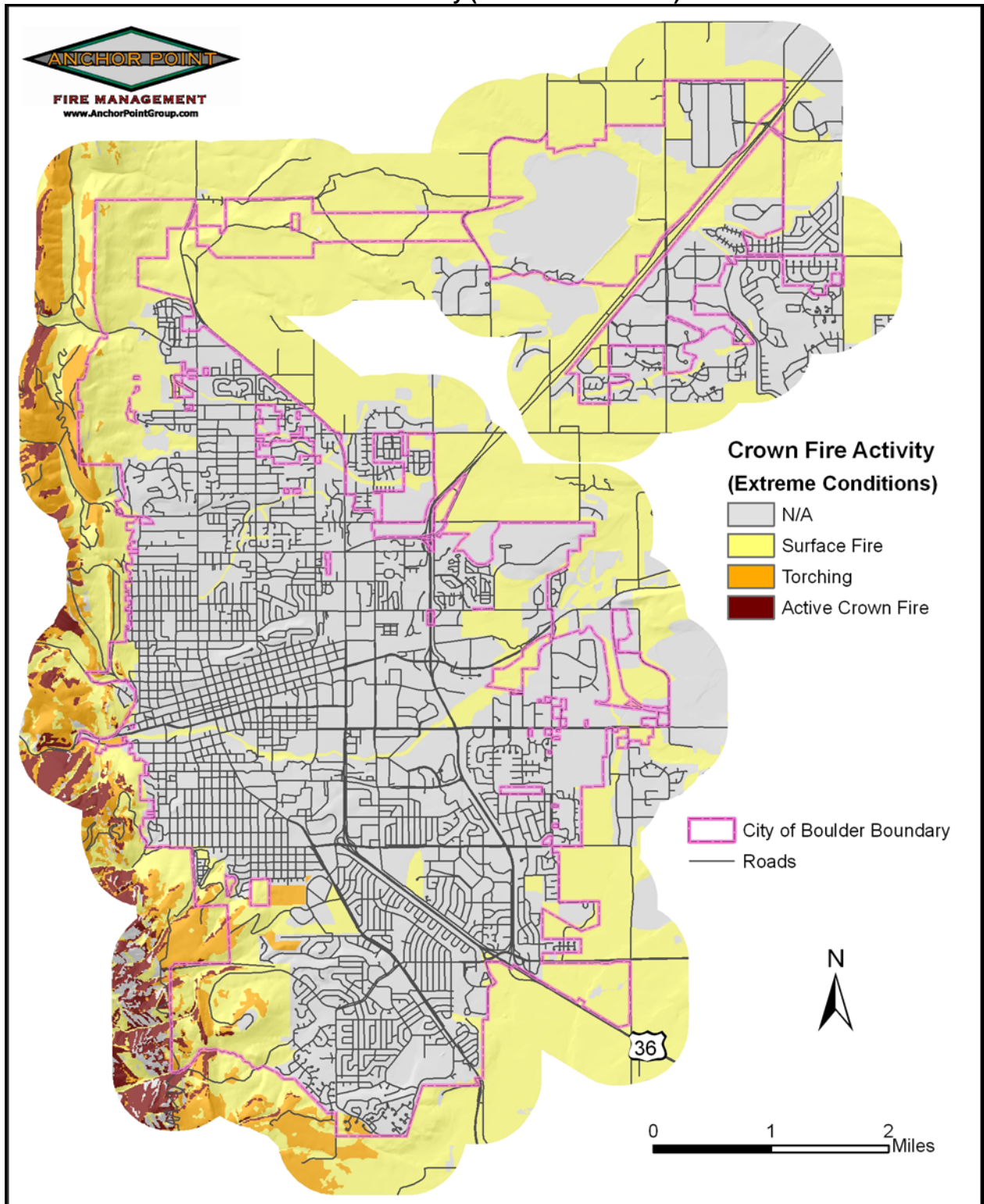
Crown fire activity, rate of spread, and flame length are derived from the fire behavior predictions. The following maps graphically display the outputs of **FlamMap** for both moderate and extreme weather conditions.

**FIGURE 14. Predictions of Crown Fire Activity (Moderate Conditions)**

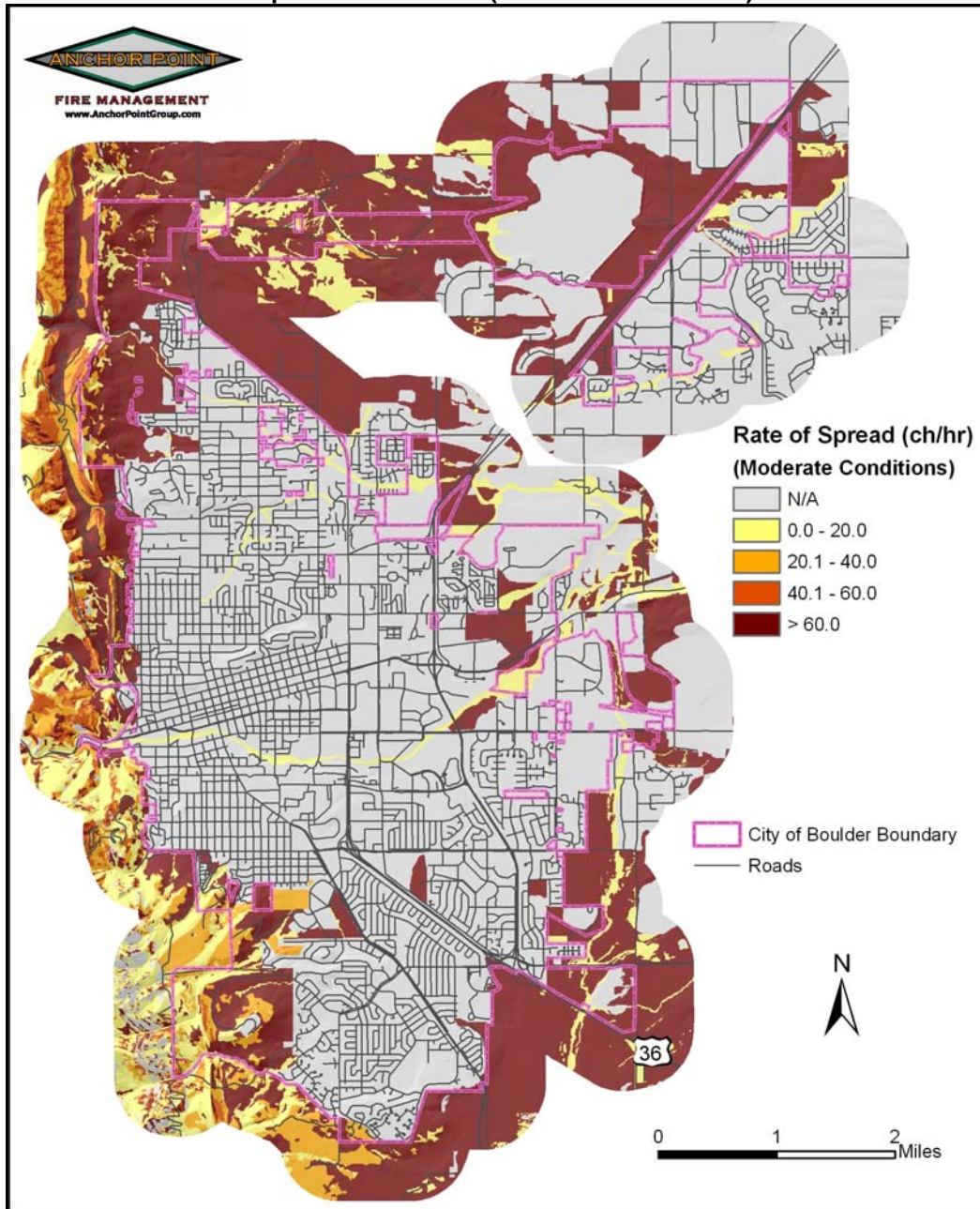


Crown fire activity values are generated by the **FlamMap** model and classified into four categories based on standard ranges: Active, Passive, Surface, and Not Applicable. In the surface fire category, little or no tree torching will be expected. During passive crown fire activity, isolated torching of trees or groups of trees will be observed and canopy runs will be limited to short distances. During active crown fire activity, sustained runs through the canopy will be observed that may be independent of surface fire activity.

FIGURE 15. Predictions of Crown Fire Activity (Extreme Conditions)



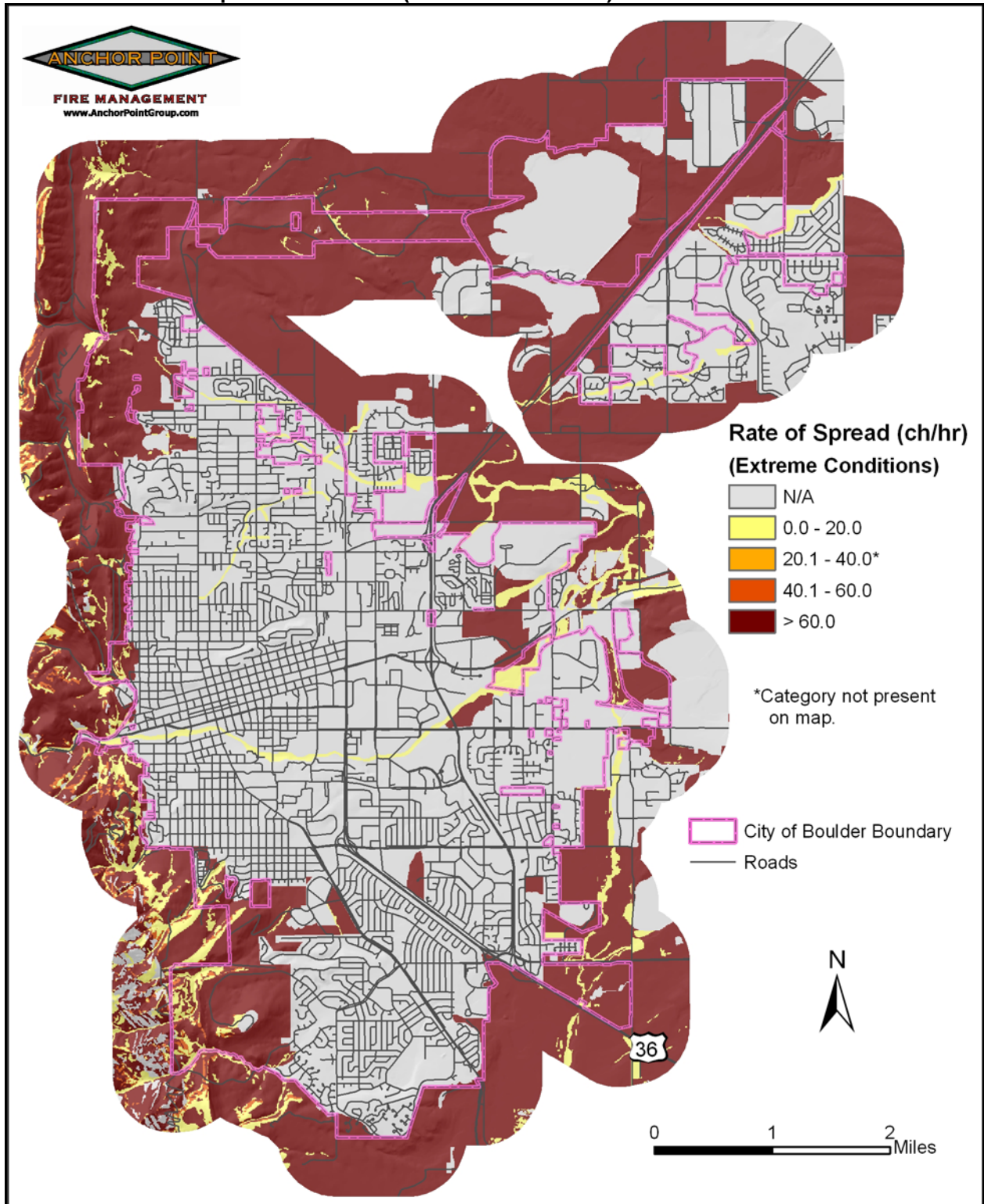
**FIGURE 16. Rate of Spread Predictions (Moderate Conditions)**



**Rate of spread in chains/hour**  
**(1 chain=66 ft) (80 chains/HR = 1 MPH)**

Spread rate values are generated by the **FlamMap** model and classified into four categories based on standard ranges: 0-20 ch/h (chains/hour), 20.1-40 ch/h, 40.1-60 ch/h, and greater than 60 ch/h. A chain is a logging measurement that is equal to 66 feet. One mile equals 80 chains. 1 ch/h equals approximately 1 foot/minute or 80 chains per hour equals 1 mile per hour.

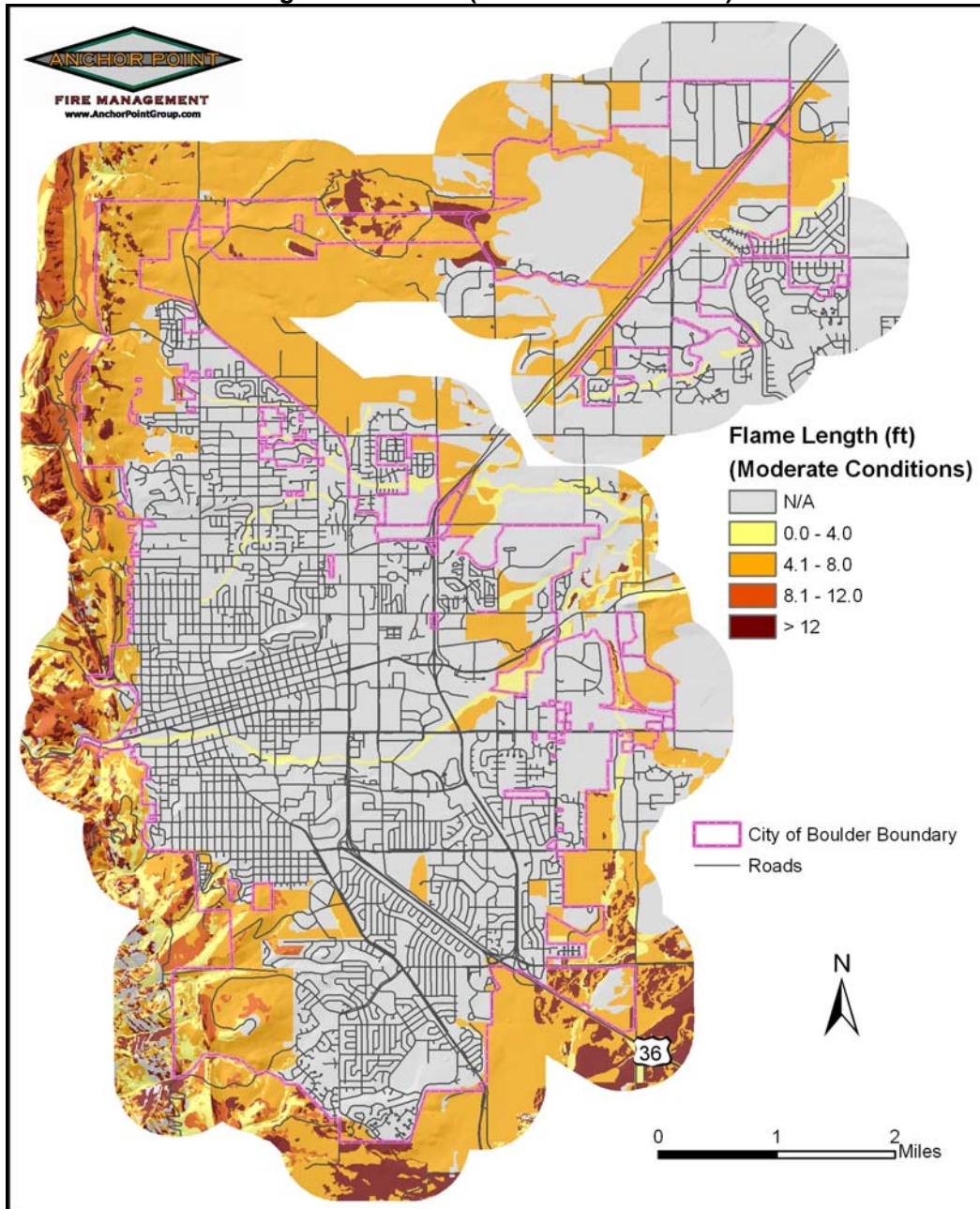
**FIGURE 17. Rate of Spread Predictions (Extreme Conditions)**



**Rate of spread in chains/hour  
 (1 chain=66 ft) (80 chains/HR = 1 MPH)**

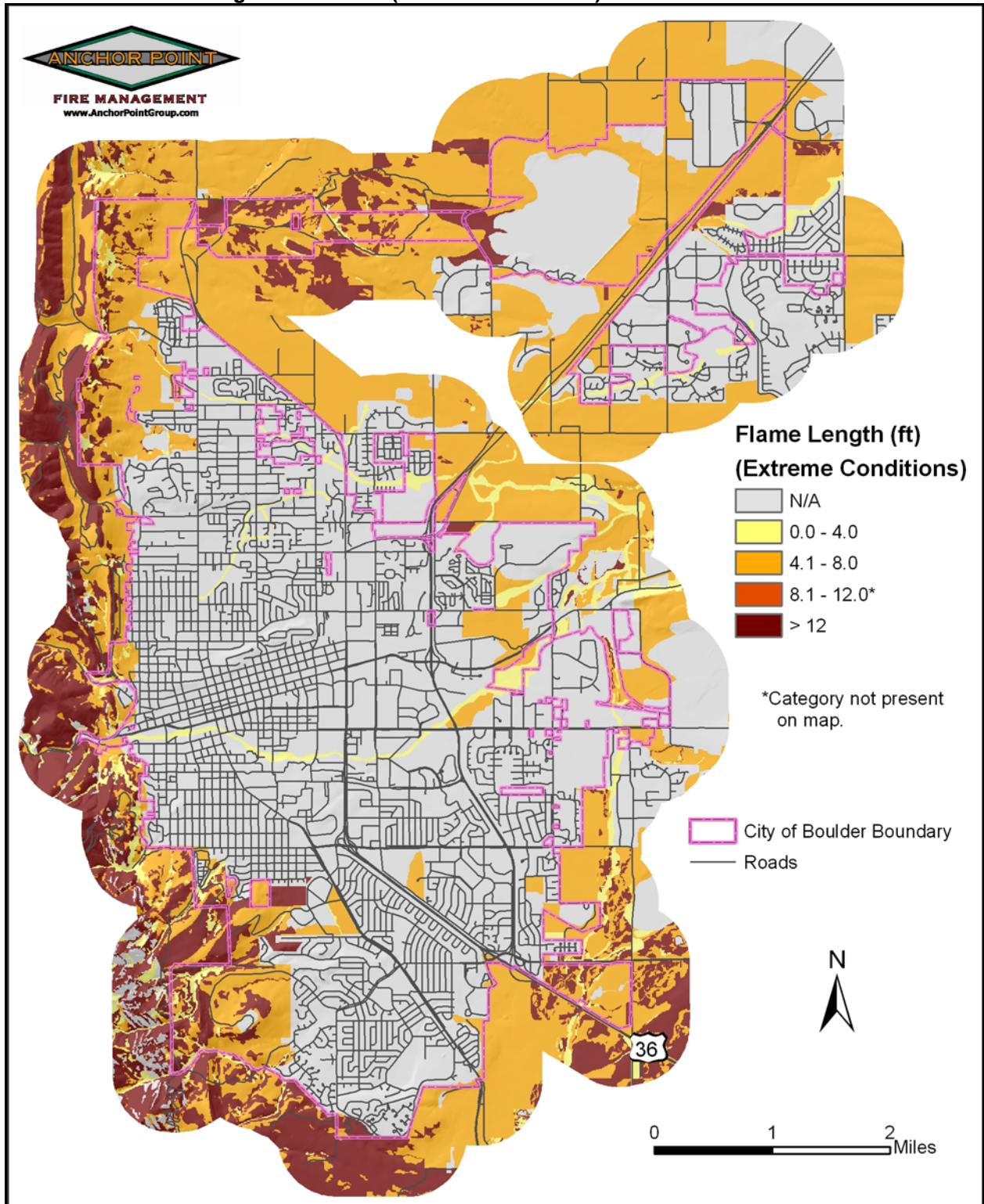


FIGURE 18. Flame Length Predictions (Moderate Conditions)



Flame length values are generated by the **FlamMap** model and classified in the four categories based on standard ranges: 0-4 feet, 4.1-8 feet, 8.1-12 feet and 12.1-60 feet. Flame lengths of 4 feet and less are acceptable for direct attack by hand crews. Flame lengths of 8 feet and less are suitable for direct attack by machinery. With flame lengths of greater than 8 feet, indirect attack and aerial attack are the preferred methods.

FIGURE 19. Flame Length Predictions (Extreme Conditions)



**Fire Behavior Interpretation and Limitations**

This evaluation is a prediction of likely fire behavior, given a standardized set of conditions and a single point source ignition at every point. It does not consider cumulative impacts of increased fire intensity over time and space. The model does not calculate the probability that a wildfire will occur. It assumes an ignition occurrence for every cell (each 10 x 10 meter area).

Weather conditions are extremely variable and all possible combinations cannot be accounted for. These outputs are best used for pre-planning and not as a stand-alone product for tactical planning. Whenever possible, fire behavior calculations should be done with actual weather observations during the fire. The most current ERC values should also be calculated and distributed during the fire season to be used as a guideline for fire behavior potential.

# CITY OF BOULDER CWPP

## APPENDIX B

### COMMUNITIES

---



The purpose of this appendix is to examine, in greater detail, the communities in the study area. Of the ten Wildland-Urban Interface communities within the City of Boulder response area, three were found to represent a very high hazard; three were rated as high hazard; two as moderate hazard, and two as low hazard (see **Figure 1**). For easy reference, the map of communities presented in the main text has been reproduced here as **Figure 2**. **Figure 3** displays this grouping graphically. **Table 1** has been included for quick identification.

FIGURE 1.

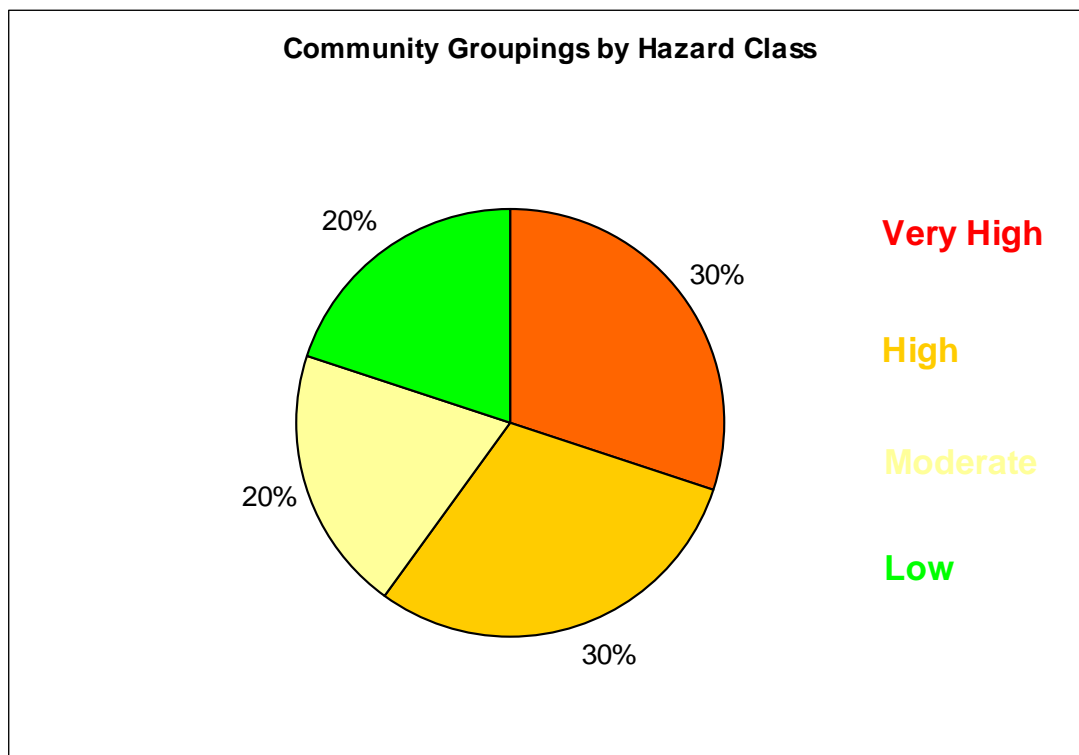


FIGURE 2.

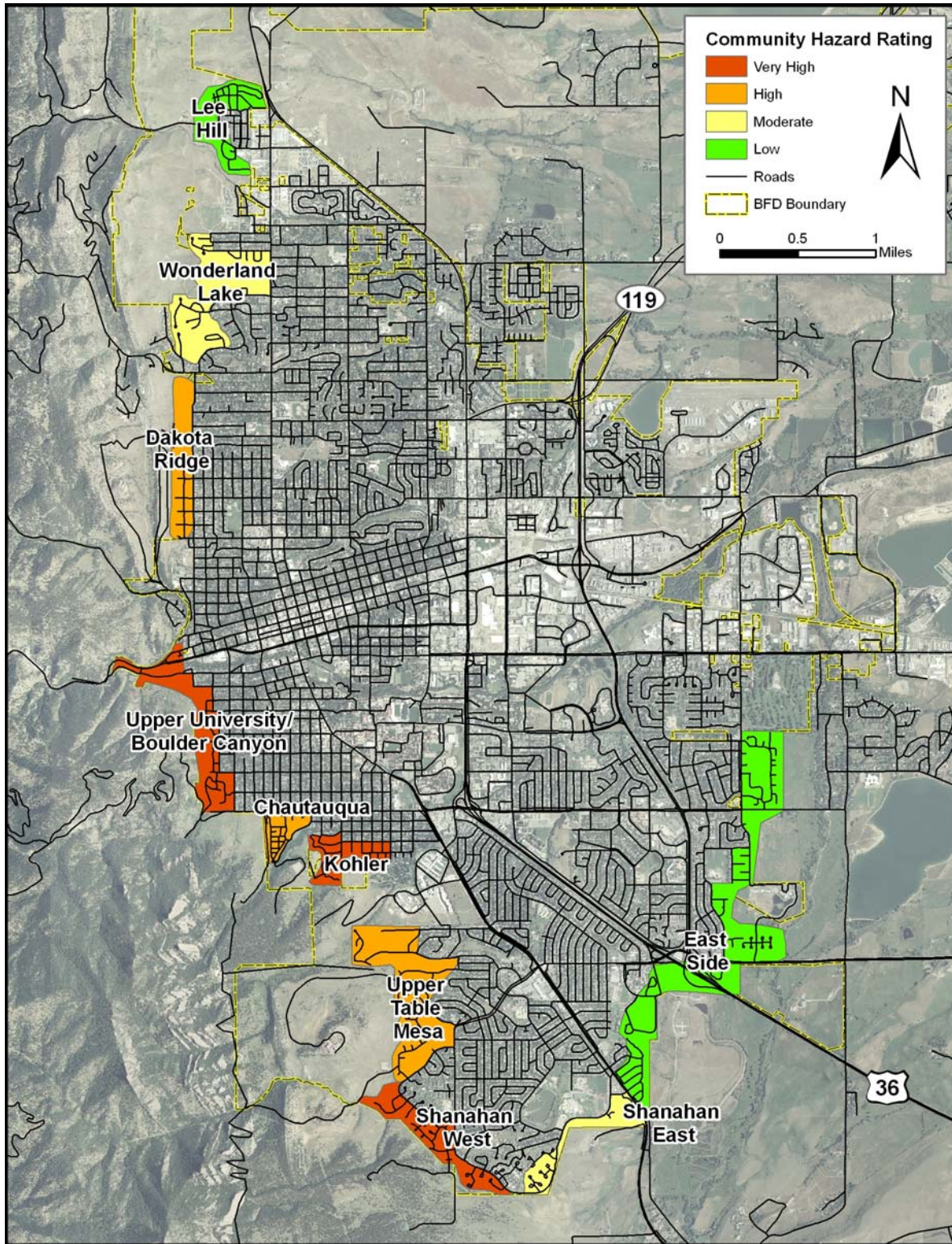


FIGURE 3.

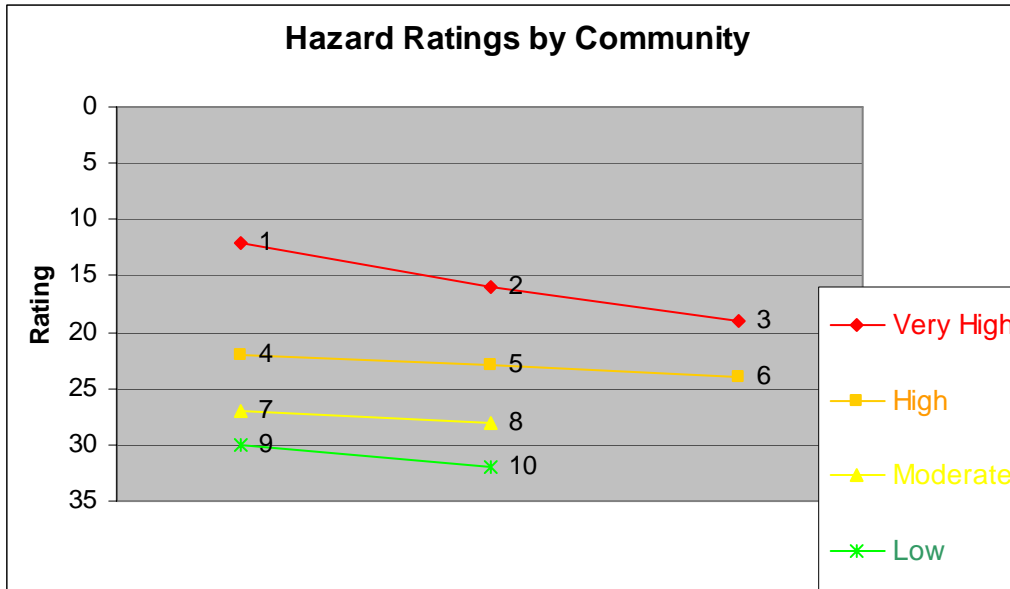


TABLE 1. Communities by Hazard Rating

Hazard Ratings for City of Boulder Communities				
Number	Community	(Ref.#) WP #	Rank	Score
1	Kohler Area		Very High	12
2	Upper University / Boulder Canyon Area		Very High	16
3	Shanahan West Area		Very High	19
4	Chautauqua		High	22
5	Upper Table Mesa Area		High	23
6	Dakota Ridge Area		High	24
7	Wonderland Lake Area		Moderate	27
8	Shanahan East Area		Moderate	28
9	East Side Area		Low	30
10	Lee Hill Area		Low	32

## General Recommendations

A combination of adequate access, ignition resistant construction, and fuels reduction should create a safe environment for emergency service personnel and provide reasonable protection to structures from a wildfire. These techniques should also significantly reduce the chances of a structure fire becoming an ignition source to the surrounding wildlands.

In addition to the suggested mitigations listed for the individual communities, several general measures can be taken to improve fire safety. The following recommendations should be noted and practiced by anyone living in the Wildland-Urban Interface:

1. Be aware of the current fire danger in the area.
2. Clean roofs and gutters at least two times a year, especially during cure-up in autumn.
3. Stack firewood uphill or on a side contour, at least 30 feet away from structures.
4. Don't store combustibles or firewood under decks.
5. Maintain and clean spark arresters on chimneys.
6. When possible, maintain an irrigated greenbelt around the home.
7. Connect, and have available, a minimum of 50 feet of garden hose.
8. Post reflective lot and/or house numbers so that they are clearly visible from the main road. Reflective numbers should also be visible on the structure itself.
9. Trees along driveways should be limbed and thinned as necessary to maintain a minimum 13'6" vertical clearance for emergency vehicle access.
10. Maintain your defensible space constantly:
  - Mow grass and weeds to a low height.
  - Remove any branches overhanging the roof or chimney.
  - Remove all trash, debris, and cuttings from the defensible space.



## Note

Individual home assessments have been completed prior to this report. The communities that rate as very high and high hazard level have been recommended for a parcel-level analysis. In the moderate level communities a parcel level analysis would only have been recommended if the evaluator found that a significant number of homes had no or ineffective defensible space or a significant number of hazards near homes was detected. In short the recommendation was made if the evaluator felt a parcel level analysis would generate a noticeable improvement in the community's defensibility.

## Technical Terms

*The following definitions apply to terms used in the community description and recommendations sections of this appendix.*

**Defensible Space:** An area around a structure where fuels and vegetation are modified, cleared, or reduced to slow the spread of wildfire toward or from the structure. The design and extent of the defensible space is based on fuels, topography, and the design and materials of the structure.

**Extended Defensible Space** (also known as Zone 3): In this defensible space zone, treatment is continued beyond the recommended minimum boundary for defensible space. This zone focuses on forest management with fuels reduction being a secondary function.

**Citizen Safety Zone:** An area that can be used by residents for protection in the event that the main evacuation route is compromised. The area should be maintained, cleared of fuels, and large enough for all residents of the area to survive an advancing wildfire without special equipment or training.

**Fuelbreak:** A natural or constructed discontinuity in a fuel profile used to segregate, stop, or reduce the spread of fire. As a practical matter, fuelbreaks in the WUI are most effective against crown fires.

## Community Assessment Methodology

The community-level methodology for this assessment uses a Wildfire Hazard Rating (WHR) that was developed specifically to evaluate communities within the Wildland Urban Interface (WUI) for their relative wildfire hazard.<sup>1</sup> The WHR model combines physical infrastructure such as structure density and roads, and fire behavior components like fuels and topography, with the field experience and knowledge of wildland fire experts. It has been proven and refined by use in rating over 1,400 neighborhoods throughout the United States.

Many knowledgeable and experienced fire management professionals were queried about specific environmental and infrastructure factors, and wildfire behavior and hazards. Weightings within the WHR model were established through these queries. The model was designed to be applicable throughout the western United States.

The model was developed from the perspective of performing structural triage on a threatened community in the path of an advancing wildfire with moderate fire behavior. The WHR survey and fuel model ground truthing are accomplished by field surveyors with WUI fire experience. The rating system assigns up to a maximum of 60 points based on seven categories:

- Average Lot Size
- Slope
- Primary Aspect
- Average Fuel Type
- Fuel Continuity
- Dominant Construction Type
- Surface Fuel Loading

The higher the score for a given community, the lower its wildfire hazard. For example, a community with an average lot size of less than 1 acre and slopes of greater than 30% would receive 0 points for those factors, whereas a community with an average lot size of 5 acres and slopes of less than 15% would receive 16 points for the same factors. Additional hazards are then subtracted from the subtotal of points earned in the seven categories to give a final numeric value. The final value is then used to group communities into one of five hazard ratings: Extreme, Very High, High, Moderate, or Low.

It is important to note that not all groupings occur in every geographic region. There are some areas with no low hazard communities, just as there are some areas with no extreme communities. The rankings are also related to what is customary for the area. For example, a high hazard area on the plains of Kansas may not look like a high hazard area in the Sierra Nevada. The system creates a relative ranking of community hazards in relation to the other communities in the study area. It is designed to be used by experienced wildland firefighters who have a familiarity with structural triage operations and fire behavior in the interface.

---

1 C. White, "Community Wildfire Hazard Rating Form" *Wildfire Hazard Mitigation and Response Plan*, Colorado State Forest Service, Ft. Collins, CO, 1986.

## Communities

### 1. Kohler Area

FIGURE 4.



**Hazard Rating:**

**Very High**

**Does the neighborhood have dual access roads?**

Yes

**Are there road grades > 8%?**

Yes

**Are all access roads of adequate width?**

Yes

**Average lot size:**

<1 acre

**Fuel models found in the neighborhood:**

1, 2, 3

**Water supply:**

Hydrants

**Hazards:**

Steep slopes, ravines, inadequate roads, power lines, open space

**Description:**

- Medium to large sized homes on mostly small lots.
- Dominant construction is wood siding with composite roofs; some IR & wood shake roofs are present.
  - Decks and other structural projections built over flammable vegetation.
- Poor and non-existent defensible space is present in some cases.
- Access is poor in some areas due to long and narrow driveways on steep grades. Bellevue Drive is narrow and in poor condition.
- Addressing overall is okay, markers are inconsistent in placement and of low visibility.
- Manmade hazards such as overhead power lines exist.

- Water supply is via the city hydrant system.
- Fuels are mostly short and tall grass in heavy loads. Some timber and brush exist.
- The community sits at the base of a steep east and north-facing slope.
  - Several homes sit mid-slope.
  - Other topographic features exist in this community.
- Boulder Open Space borders the community on the south side.

## Kohler Area Recommendations

- A parcel-level analysis is recommended. Completed individual home assessments should be incorporated in future documents.
- Adequate defensible space is recommended for all homes (see **Home Mitigation FMU** in the main report for details).
- Extended defensible space is recommended for homes located in dangerous topography (above natural chimneys, mid-slope on steep slopes, or on summits) with heavy fuel loads near or below the home.
- Discourage the use of combustible materials for decks, siding, and roofs, especially where homes are upslope from heavy fuels. Replace all shake roofs with non-combustible types such as metal or composite shingle.
- Open areas below decks and projections should be enclosed or screened to prevent the ingress of embers, and kept clean of flammable materials, especially where such openings are located on slopes above heavy fuels.
- Clean leaf and needle litter from roofs and gutters and away from foundations. Clear flammable vegetation away from power lines near homes.
- Discourage the planting of flammable ornamentals such as conifers within 30 feet of homes. Encourage the use of fire- and drought-tolerant plants for ornamental plantings, especially within 30 feet of homes (see the **Home Mitigation FMU** section in the main report).
- Thin vegetation along access roads and driveways. This is especially important for narrow driveways (see the “Access Route Fuels Modification Recommendations” located in the **Fuels Modification Projects FMU** section of the main report).
- Remove low hanging branches on pine trees that are within 100’ of homes (see **Home Mitigation FMU** in the main report for details).
- Where slopes rise steeply, consider creating barriers such as rock walls to protect areas from burning, rolling material.
- Wherever possible, add pullouts for emergency apparatus on driveways and private roads longer than 300 feet. Turnarounds should be constructed at the end of all driveways.
- Add reflective addressing to all driveways and homes.
- Make certain all fire hydrants are visible.

## 2. Upper University / Boulder Canyon Area

FIGURE 5.



**Hazard Rating:**

**Very High**

**Does the neighborhood have dual access roads?**

Yes

**Are there road grades > 8%?**

Yes

**Are all access roads of adequate width?**

Yes

**Average lot size:**

<1 acre

**Fuel models found in the neighborhood:**

1, 2, 3

**Water supply:**

Hydrants

**Hazards:**

Steep slopes, ravines, inadequate roads, power lines, open space

**Description:**

- Medium to large sized homes on mostly small lots.
- Dominant construction is wood siding with composite roofs; some IR & wood shake roofs are present.
  - Decks and other structural projections built over flammable vegetation.
- Poor and non-existent defensible space is present in some cases.
  - Some outbuildings exist.
- Access is poor in some areas due to long and narrow driveways.
- Addressing overall is okay, but markers are inconsistent in placement and hard to locate.
  - Some homes in the Canyon Blvd and Arapahoe Ave area do not have posted address signs.
- Manmade hazards such as overhead power lines exist.

- Water supply is via the city hydrant system.
- Fuels are mostly short and tall grass in heavy loads. Some timber and brush exist.
  - A heavily vegetated riparian corridor exists behind the homes on University and Arapahoe Avenues.
- The community sits at the base of steep slopes with most aspects present.
  - Several homes sit mid slope.
  - Other topographic features exist in this community.
- Boulder Open Space borders the community.

## Upper University / Boulder Canyon Area Recommendations

- A parcel-level analysis is recommended. Completed individual home assessments should be incorporated into future documents.
- Adequate defensible space is recommended for all homes (see **Home Mitigation FMU** in the main report for details).
- Extended defensible space is recommended for homes located in dangerous topography (mid-slope) with heavy fuel loads near or below the home.
- Discourage the use of combustible materials for decks, siding, and roofs, especially where homes are upslope from heavy fuels. Replace all shake roofs with non-combustible types such as metal or composite shingle.
- Open areas below decks and projections should be enclosed or screened to prevent the ingress of embers, and kept clean of flammable materials, especially where such openings are located on slopes above heavy fuels.
- Clean leaf and needle litter from roofs and gutters and away from foundations. Clear flammable vegetation away from power lines near homes.
- Discourage the planting of flammable ornamentals such as conifers within 30 feet of homes. Encourage the use of fire- and drought-tolerant plants for ornamental plantings, especially within 30 feet of homes (see the **Home Mitigation FMU** section in the main report).
- Thin vegetation along access roads and driveways. This is especially important for narrow driveways (see the “Access Route Fuels Modification Recommendations” located in the **Fuels Modification Projects FMU** section of the main report).
- Remove low hanging branches on pine trees that are within 100’ of homes (see **Home Mitigation FMU** in the main report for details).
- Where slopes rise steeply, consider creating barriers such as rock walls to protect areas from burning, rolling material.
- Wherever possible, add pullouts for emergency apparatus on driveways and private roads longer than 300 feet. Turnarounds should be constructed at the end of all driveways.
- Add reflective addressing to all driveways and homes.
- Make certain all fire hydrants are visible.



### 3. Shanahan West Area

FIGURE 6.



**Hazard Rating:**

**Very High**

**Does the neighborhood have dual access roads?**

Yes

**Are there road grades > 8%?**

No

**Are all access roads of adequate width?**

Yes

**Average lot size:**

<1 acre

**Fuel models found in the neighborhood:**

1, 2, 3

**Water supply:**

Hydrants

**Hazards:**

Ravines, wood roofs, open space

**Description:**

- Medium to large sized homes on mostly small lots.
- Dominant construction is wood siding with composite roofs; some IR & wood shake roofs are present.
  - Decks and other structural projections built over flammable vegetation.
- Defensible space ranges from good to poor.
  - Some outbuildings exist.
- Access is good.
- Addressing is okay, but markers are inconsistent in placement and hard to locate.
- Water supply is via the city hydrant system.
- Fuels are mostly short and tall grass in heavy loads. Some timber and brush exist.

- The community sits at the base of an east-facing slope.
- Other topographic features exist in this community.
- Boulder Open Space borders the community on the west side.

## Shanahan West Area Recommendations

- ❑ A parcel-level analysis is recommended. Completed individual home assessments should be incorporated in future documents.
- ❑ Adequate defensible space is recommended for all homes (see **Home Mitigation FMU** in the main report for details).
- ❑ Discourage the use of combustible materials for decks, siding, and roofs, especially where homes are upslope from heavy fuels. Replace all shake roofs with non-combustible types such as metal or composite shingle.
- ❑ Open areas below decks and projections should be enclosed or screened to prevent the ingress of embers, and kept clean of flammable materials, especially where such openings are located on slopes above heavy fuels.
- ❑ Clean leaf and needle litter from roofs and gutters and away from foundations.
- ❑ Discourage the planting of flammable ornamentals such as conifers within 30 feet of homes. Encourage the use of fire- and drought-tolerant plants for ornamental plantings, especially within 30 feet of homes (see the **Home Mitigation FMU** section in the main report).
- ❑ Thin vegetation along access roads and driveways. This is especially important for narrow driveways (see the “Access Route Fuels Modification Recommendations” located in the **Fuels Modification Projects FMU** section of the main report).
- ❑ Remove low hanging branches on pine trees that are within 100’ of homes (see **Home Mitigation FMU** in the main report for details).
- ❑ Add reflective addressing to all driveways and homes.
- ❑ Make certain all fire hydrants are visible.

#### 4. Chautauqua

FIGURE 7.



**Hazard Rating:**

**High**

**Does the neighborhood have dual access roads?**

Yes

**Are there road grades > 8%?**

Yes

**Are all access roads of adequate width?**

No

**Average lot size:**

<1 Acre

**Fuel models found in the neighborhood:**

1, 3, 8

**Water supply:**

Hydrants

**Hazards:**

Power lines, steep slopes, open space

**Description:**

- Small cottages on small lots.
- Construction is older wood siding with composite roofs.
  - Decks built over flammable vegetation.
- Defensible space is mostly poor.
  - Some outbuildings exist.
- Access is good, but narrow and steep.
- Addressing is okay, markers are inconsistent in placement and of low visibility.
- Water supply is via the city hydrant system.
- Fuels are mostly short and tall grass in heavy loads. A heavily vegetated riparian corridor exists on the south side.

- The community sits on a lower north-facing slope.
- Boulder Open Space borders the community on most sides.

## Chautauqua Recommendations

- A parcel-level analysis is recommended. Completed individual home assessments should be incorporated in future documents.
- Adequate defensible space is recommended for all homes (see **Home Mitigation FMU** in the main report for details).
- Discourage the use of combustible materials for decks and siding especially where homes are upslope from heavy fuels.
- Open areas below decks and projections should be enclosed or screened to prevent the ingress of embers, and kept clean of flammable materials, especially where such openings are located on slopes above heavy fuels.
- Clean leaf and needle litter from roofs and gutters and away from foundations. Clear flammable vegetation away from power lines near homes.
- Discourage the planting of flammable ornamentals such as conifers within 30 feet of homes. Encourage the use of fire- and drought-tolerant plants for ornamental plantings, especially within 30 feet of homes (see the **Home Mitigation FMU** section in the main report).
- Thin vegetation along access roads and driveways. This is especially important for narrow driveways (see the “Access Route Fuels Modification Recommendations” located in the **Fuels Modification Projects FMU** section of the main report).
- Add reflective addressing to all homes.
- Make certain all fire hydrants are visible.

## 5. Upper Table Mesa Area

FIGURE 8.



**Hazard Rating:**

**High**

**Does the neighborhood have dual access roads?**

Yes

**Are there road grades > 8%?**

No

**Are all access roads of adequate width?**

Yes

**Average lot size:**

<1 acre

**Fuel models found in the neighborhood:**

1, 3

**Water supply:**

Hydrants

**Hazards:**

Steep slopes, ravines, open space

**Description:**

- Medium to large sized homes on mostly small lots.
- Dominant construction is wood siding with composite roofs; some IR & wood shake roofs are present.
  - Decks and other structural projections built over flammable vegetation.
- Defensible space ranges from good to poor.
  - Some outbuildings exist.
- Access is good.
- Addressing is okay, but markers are inconsistent in placement and hard to locate.
- Water supply is via the city hydrant system.
- Fuels are mostly short and tall grass in heavy loads. Some timber and brush exist.

- The community sits at the base of an east and north facing slopes.
  - Other topographic features exist in this community.
- Boulder Open Space borders the community on the west side.



## Upper Table Mesa Area Recommendations

- A parcel-level analysis is recommended. Completed individual home assessments should be incorporated in future documents.
- Adequate defensible space is recommended for all homes (see **Home Mitigation FMU** in the main report for details).
- Discourage the use of combustible materials for decks, siding, and roofs, especially where homes are upslope from heavy fuels. Replace all shake roofs with non-combustible types such as metal or composite shingle.
- Open areas below decks and projections should be enclosed or screened to prevent the ingress of embers, and kept clean of flammable materials, especially where such openings are located on slopes above heavy fuels.
- Clean leaf and needle litter from roofs and gutters and away from foundations.
- Discourage the planting of flammable ornamentals such as conifers within 30 feet of homes. Encourage the use of fire- and drought-tolerant plants for ornamental plantings, especially within 30 feet of homes (see the **Home Mitigation FMU** section in the main report).
- Thin vegetation along access roads and driveways. This is especially important for narrow driveways (see the “Access Route Fuels Modification Recommendations” located in the **Fuels Modification Projects FMU** section of the main report).
- Remove low hanging branches on pine trees that are within 100’ of homes (see **Home Mitigation FMU** in the main report for details).
- Add reflective addressing to all driveways and homes.
- Make certain all fire hydrants are visible.

## 6. Dakota Ridge Area

FIGURE 9.



<b>Hazard Rating:</b>	<b>High</b>
<b>Does the neighborhood have dual access roads?</b>	Yes
<b>Are there road grades &gt; 8%?</b>	No
<b>Are all access roads of adequate width?</b>	Yes
<b>Average lot size:</b>	<1 acre
<b>Fuel models found in the neighborhood:</b>	1, 3, 8
<b>Water supply:</b>	Hydrants
<b>Hazards:</b>	Open space

### Description:

- Medium sized to large homes on mostly small lots.
- Dominant construction is wood siding with composite roofs; some IR & wood shake roofs are present.
  - Decks and other structural projections built over flammable vegetation.
- Defensible space ranges from good to poor.
  - Some outbuildings exist.
- Access is good.
- Addressing is okay, but markers are inconsistent in placement and hard to locate.
- Water supply is via the city hydrant system.
- Fuels are mostly short and tall grass in heavy loads. Some timber and brush exist.

- A heavily vegetated riparian corridor exists behind the homes.
- The community sits at the base of an east-facing slope.
  - Other topographic features exist in this community.
- Boulder Open Space borders the community on the west side.

## Dakota Ridge Area Recommendations

- ❑ A parcel-level analysis is recommended. Completed individual home assessments should be incorporated in future documents.
- ❑ Adequate defensible space is recommended for all homes (see **Home Mitigation FMU** in the main report for details).
- ❑ Discourage the use of combustible materials for decks, siding, and roofs, especially where homes are upslope from heavy fuels. Replace all shake roofs with non-combustible types such as metal or composite shingle.
- ❑ Open areas below decks and projections should be enclosed or screened to prevent the ingress of embers, and kept clean of flammable materials, especially where such openings are located on slopes above heavy fuels.
- ❑ Clean leaf and needle litter from roofs and gutters and away from foundations.
- ❑ Discourage the planting of flammable ornamentals such as conifers within 30 feet of homes. Encourage the use of fire- and drought-tolerant plants for ornamental plantings, especially within 30 feet of homes (see the **Home Mitigation FMU** section in the main report).
- ❑ Thin vegetation along access roads and driveways. This is especially important for narrow driveways (see the “Access Route Fuels Modification Recommendations” located in the **Fuels Modification Projects FMU** section of the main report).
- ❑ Remove low hanging branches on pine trees that are within 100’ of homes (see **Home Mitigation FMU** in the main report for details).
- ❑ Add reflective addressing to all driveways and homes.
- ❑ Make certain all fire hydrants are visible.

## 7. Wonderland Lake Area

FIGURE 10.



**Hazard Rating:**

Moderate

**Does the neighborhood have dual access roads?**

Yes

**Are there road grades > 8%?**

No

**Are all access roads of adequate width?**

Yes

**Average lot size:**

<1 acre

**Fuel models found in the neighborhood:**

1 & 3

**Water supply:**

Hydrants

**Hazards:**

Open space

**Description:**

- Medium sized homes on mostly small lots.
- Construction is wood siding with composite roofs.
  - Decks and other structural projections built over flammable vegetation.
- Defensible space ranges from good to poor.
  - Some outbuildings exist.
- Access is good.
- Addressing is okay, markers are inconsistent in placement and of low visibility.
- Water supply is via the city hydrant system.
- Fuels are mostly short and tall grass in heavy loads.
  - Riparian areas exist.

- The community sits at the base of an east-facing slope.
  - Other topographic features exist in this community.
- Boulder Open Space borders the community on the west side.

## Wonderland Lake Area Recommendations

- Adequate defensible space is recommended for all homes (see **Home Mitigation FMU** in the main report for details).
- Discourage the use of combustible materials for decks and siding.
- Open areas below decks and projections should be enclosed or screened to prevent the ingress of embers, and kept clean of flammable materials.
- Clean leaf and needle litter from roofs and gutters and away from foundations.
- Discourage the planting of flammable ornamentals such as conifers within 30 feet of homes. Encourage the use of fire- and drought-tolerant plants for ornamental plantings, especially within 30 feet of homes (see the **Home Mitigation FMU** section in the main report).
- Add reflective addressing to all driveways and homes.
- Make certain all fire hydrants are visible.

## 8. Shanahan East Area

FIGURE 10.



**Hazard Rating:**

**Moderate**

**Does the neighborhood have dual access roads?**

Yes

**Are there road grades > 8%?**

No

**Are all access roads of adequate width?**

Yes

**Average lot size:**

<1 acre

**Fuel models found in the neighborhood:**

1

**Water supply:**

Hydrants

**Hazards:**

**Description:**

- Medium sized single and multi-family homes on mostly small lots.
- Construction is wood siding with composite roofs.
  - Decks and other structural projections built over flammable vegetation.
- Defensible space is mostly good.
  - Some outbuildings exist.
- Access is good.
- Addressing is okay, but markers are inconsistent in placement and hard to locate.
- Water supply is via the city hydrant system.
- Fuels are mostly short grass. Some pockets of tall grass in heavy loads exist.



- The community sits back from a short slope on a south aspect.
- Boulder Open Space borders some of the community on the south side.

## Shanahan East Area Recommendations

- Adequate defensible space is recommended for all homes, especially those located on the perimeter (see the **Plains Communities FMU** and **Home Mitigation FMU** in the main report for details).
- Discourage the use of combustible materials for decks and siding.
- Open areas below decks and projections should be enclosed or screened to prevent the ingress of embers, and kept clean of flammable materials.
- Clean leaf and needle litter from roofs and gutters and away from foundations.
- Discourage the planting of flammable ornamentals such as conifers within 30 feet of homes. Encourage the use of fire- and drought-tolerant plants for ornamental plantings, especially within 30 feet of homes (see the **Plains Communities FMU** and **Home Mitigation FMU** sections in the main report).
- Add reflective addressing to all driveways and homes.
- Make certain all fire hydrants are visible.

## 9. East Side Area

FIGURE 11.



<b>Hazard Rating:</b>	<b>Low</b>
<b>Does the neighborhood have dual access roads?</b>	Yes
<b>Are there road grades &gt; 8%?</b>	No
<b>Are all access roads of adequate width?</b>	Yes
<b>Average lot size:</b>	<1 acre
<b>Fuel models found in the neighborhood:</b>	1 & 3
<b>Water supply:</b>	Hydrants
<b>Hazards:</b>	Power lines, open space

### Description:

- Small to medium homes on small sized lots.
- Homes are a mix of new and old construction. Wood siding with composite roofs, a couple wooden roofs.
- Defensible space is okay overall. Flammable ornamental vegetation is too close to structures. Some yard clutter.
- Access is good.
- Addressing is okay, but markers are inconsistent in placement and hard to locate.
- Manmade hazards such as overhead power lines exist.
- Water supply is via the city hydrant system.
- Fuels are mostly short grass. Some pockets of tall grass in heavy loads exist.

- Riparian areas exist.
- Topography is mostly flat; a few short slopes exist.
- Boulder Open Space borders most of the community.

## East Side Area Recommendations

- Adequate defensible space is recommended for all homes, especially those located on the perimeter (see the **Plains Communities FMU** and **Home Mitigation FMU** in the main report for details).
- Discourage the use of combustible materials for decks, siding, and roofing.
- Open areas below decks and projections should be enclosed or screened to prevent the ingress of embers, and kept clean of flammable materials.
- Clean leaf and needle litter from roofs and gutters and away from foundations.
- Discourage the planting of flammable ornamentals such as conifers within 30 feet of homes. Encourage the use of fire- and drought-tolerant plants for ornamental plantings, especially within 30 feet of homes (see the **Plains Communities FMU** and **Home Mitigation FMU** sections in the main report).
- Add reflective addressing to all driveways and homes.
- Make certain all fire hydrants are visible.

## 10. Lee Hill Area

FIGURE 11.



<b>Hazard Rating:</b>	<b>Low</b>
<b>Does the neighborhood have dual access roads?</b>	Yes
<b>Are there road grades &gt; 8%?</b>	No
<b>Are all access roads of adequate width?</b>	Yes
<b>Average lot size:</b>	<1 acre
<b>Fuel models found in the neighborhood:</b>	1 & 3
<b>Water supply:</b>	Hydrants
<b>Hazards:</b>	Open space

### Description:

- Medium and large homes on small lots.
- Homes are mostly newer construction. 50% are wood siding with composite roofs, 50% are IR.
- Defensible space is excellent overall. A small group of IR constructed homes have poor defensible space.
- Access is good.
- Addressing is okay, markers are inconsistent in placement and of low visibility.
- Water supply is via the city hydrant system.
- Fuels are mostly short grass. Some pockets of tall grass in heavy loads exist.
  - Riparian areas exist.

- Topography is mostly flat; a few short slopes exist.
- Boulder Open Space borders most of the community.

## Lee Hill Area Recommendations

- Adequate defensible space is recommended for all homes, especially those located on the perimeter (see the **Plains Communities FMU** and **Home Mitigation FMU** in the main report for details).
- Discourage the use of combustible materials for decks, siding, and roofing.
- Open areas below decks and projections should be enclosed or screened to prevent the ingress of embers, and kept clean of flammable materials.
- Clean leaf and needle litter from roofs and gutters and away from foundations.
- Discourage the planting of flammable ornamentals such as conifers within 30 feet of homes. Encourage the use of fire- and drought-tolerant plants for ornamental plantings, especially within 30 feet of homes (see the **Plains Communities FMU** and **Home Mitigation FMU** sections in the main report).
- Add reflective addressing to all driveways and homes.
- Make certain all fire hydrants are visible.



# City of BOULDER CWPP

## APPENDIX C

### STRUCTURAL TRIAGE AND PREPARATION

---

#### Size Up Considerations

- What is the current and expected weather?
- Are fuels heavy, moderate, or light? What is the arrangement and continuity of fuels?
- Note any hazardous topography.
- What have fires in this area done before?
- What is the fire's current and expected behavior?
  - What is the rate and direction of spread?
  - What is the potential for spotting and firebrands?
  - Will topographical features or expected weather changes affect the rate of spread?
- What are the number and density of structures threatened?
- What are the available resources?
- Will you have to evacuate people or animals?
  - Are there residents who will not evacuate?
- How hazardous is the structure?
  - What is the roofing material?
  - Are the gutters full of litter?
  - Are there open eaves and unscreened vents?
  - Does the structure have wooden decking?
  - Is there defensible space?
  - Are there large windows with flammable drapes or curtains?
  - What is the size and location of propane tanks and/or fuel storage tanks?

#### Fire Fighter Safety

- What are the routes of egress and ingress?
  - What is the largest engine that can access the structure safely?
  - Are the roads two-way or one-way?
  - Are there road grades steeper than 8%?
  - Are the road surfaces all-weather?
  - Are there load-limited bridges?
- Are there anchor points for line construction?
- Are there adequate safety zones?
- What are the escape routes?
- Are there special hazards such as hazardous materials, explosives, high-voltage lines, or above ground fuel tanks?
- Are communications adequate?

#### Structural Triage Categories

Sort structures into one of three categories:

- 1. Stand Alone or Not Threatened**
- 2. Defendable**
- 3. Not Defendable.**

- Factors that may make an attempt to save a structure too dangerous or hopeless:
  - The fire is making sustained runs in live fuels and there is little or no defensible space
  - Spot fires are too numerous to control with existing resources
  - Water supply will be exhausted before the threat has passed
  - The roof is more than ¼ involved in flames
  - There is fire inside the structure
  - Rapid egress from the area is dangerous or may be delayed

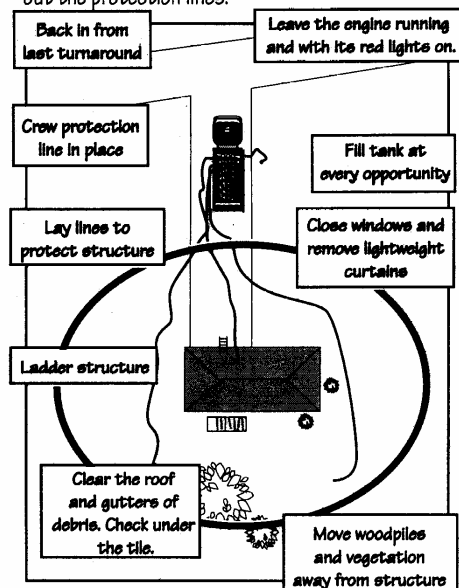
## Apparatus Placement Considerations

### Common Ignition Points

- Flammable roof coverings and debris
- Unscreened vents, windows, or holes
- Open doors, windows, or crawl spaces
- Wooden decks, lawn furniture, stacked wood, and trash piles
- In windy conditions, firebrands can enter almost any opening
- Openings under porches or patio covers

### ENGINE POSITIONING AND SETUP

It is critical that you position you, your personnel and apparatus in positions to protect the structure, but also so that you can make a quick move, if necessary. Prepare the structure and lay out the protection lines.



1

# CITY OF BOULDER CWPP

## APPENDIX D

### ACCESS AND ADDRESSING RECOMMENDED GUIDELINES

---

#### **Introduction**

This appendix has been designed with public education in mind. It should be used to help familiarize homeowners, contractors, and developers with the general principles of the access and water supply needs of firefighters. The recommendations in this section are based on proven practices. However, they are not intended to be a substitute for locally adopted codes.

Emergency response personnel do their best to respond to calls in a timely manner, often while negotiating difficult terrain. Planning for access by emergency equipment allows for a more efficient response, improving safety for residents and their families, as well as that of the firefighters and emergency medical technicians that will arrive on scene.

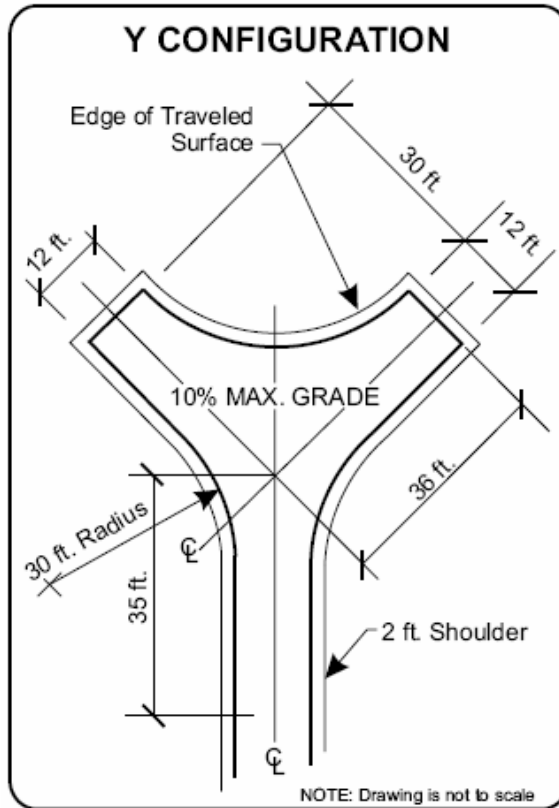
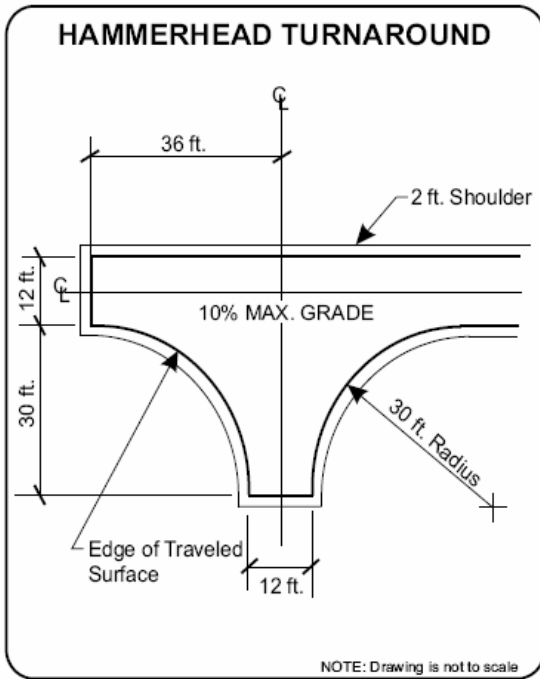
#### **Access Guidelines**

##### **Driveway Turnarounds**

Turnarounds that are unobstructed by parked vehicles are designed to allow for the safe reversal of direction by emergency equipment. The “Y” and “Hammerhead” turnarounds shown below are preferred because they provide the necessary access, while minimizing disturbance to the site. Turnarounds should be located at the end of every driveway.

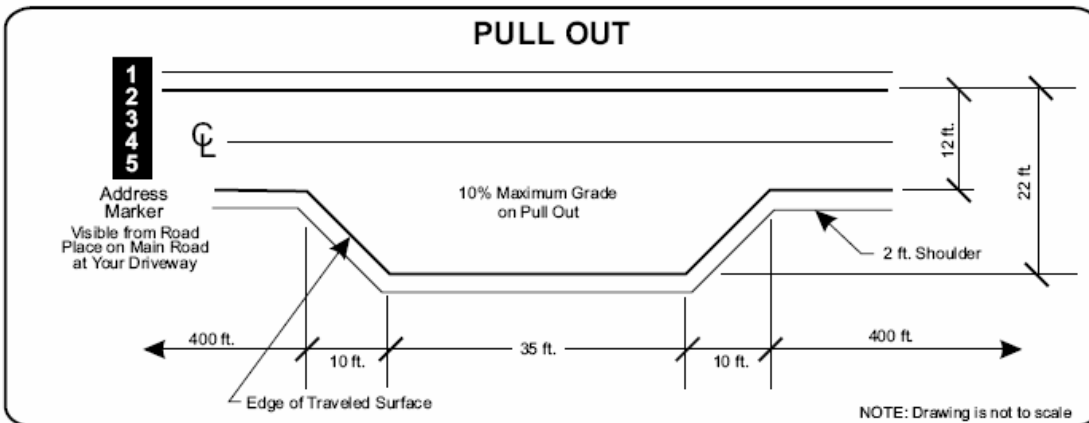
##### **Driveway Width and Height**

Driveways should have an unobstructed vertical clearance of 13' 6". Trees may need to be limbed and utility lines relocated to provide the necessary clearance. Driveways should have a 12' wide drivable surface and 14' of horizontal clearance.



## Driveway Pullouts

Driveway pullouts are designed with sufficient length and width to allow emergency vehicles to pass one another during emergency operations. These features should be placed at 400' intervals along driveways and private access roads (community driveways). The location of pullouts may be modified slightly to accommodate physical barriers such as rock outcroppings, wetlands, and other natural or manmade features.



## **Address Markers**

Every building should have a permanently posted, reflective address marker mounted on a non-combustible pole. The sign should be placed and maintained at each driveway entrance. Care should be taken to ensure that the location will not become obscured by vegetation, snow, or other features, whether natural or manmade. It is critical that the location and markings are adequate for easy night-time viewing. It is preferable to locate markers in a consistent manner within each community. A good guideline for this practice is to place the markers five feet above ground level on the right side of every driveway. Where multiple homes are accessed by a single driveway, all addresses that are accessed via that driveway should be clearly listed on the driveway marker. Where multi-access driveways split, each fork should indicate all the residences that are accessed by that fork, and the proper direction of travel to arrive at a given address. It is not adequate simply to mark addresses on a common pole in the center of the fork. Residential homes should have an additional reflective address marker permanently attached to the home in clear view of the driveway or access road. Homes that are marked by lot number while under construction should have the lot number removed and a permanent address marker posted before granting a certificate of occupancy.

## **Bridge Load Limits**

Bridge load limits should be posted with a permanently mounted, reflective marker at both entrances to the bridge. Care should be taken to ensure that these markers will not become obscured by vegetation, snow, or other features, whether natural or manmade. It is critical that the location of the markings and the markings themselves be adequate for easy night-time viewing.

---

# Appendix E

---

## City of Boulder Collaborative Effort

### The Need for a CWPP

In response to the Healthy Forest Restoration Act (HFRA), and in an effort to create incentives, Congress directed interface communities to prepare a Community Wildfire Protection Plan (CWPP). Once completed, a CWPP provides statutory incentives for the US Forest Service (USFS) to consider the priorities of local communities as they develop and implement forest management and hazardous fuel reduction projects. In the case of the City of Boulder (BFD), the need for a community-based hazard and risk assessment (HRA) was born from an internal need, not a federal directive.

CWPPs can take a variety of forms, based on the needs of the people involved in their development. CWPPs may address issues such as wildfire response, hazard mitigation, community preparedness, structure protection, or all of the above.

The minimum requirements for a CWPP are:

- Collaboration between local and state government representatives, in consultation with federal agencies and other interested parties.
- Prioritized fuel reduction in identified areas, as well as recommendations for the type and methods of treatments
- Recommendations and treatment measures for homeowners and communities to reduce the ignitability of those structures in the project area.

### Project Funding and Coordination

The City of Boulder used internal budgets in combination with a CSFS grant to complete a district-wide hazard and risk assessment and the resultant CWPP.

Future community education and private landowner assistance will be coordinated through the BFD. The BFD will continue to be instrumental in public education related to wildfire hazard reduction. The fire district will continue to identify funding for the implementation of mitigation projects. A BFD representative will coordinate all community-wide mitigation projects. Homeowner cooperation and permission for projects on private land is more likely if there is a fire district representative overseeing the details in partnership with CSFS and City/County representatives. This collaborative management structure allows for more effective implementation of cross-boundary projects.

### Inter-Agency Collaboration

## Roles and Responsibilities

To be successful, wildfire mitigation in the interface must be a community-based, collaborative effort. Stakeholders and, primarily, the BFD, will have the greatest responsibility for implementing the recommended mitigation projects. The CSFS and the City and County of Boulder will also be valuable participants in addressing cross-boundary projects throughout the district. Nearly all of the recommendations from this report affect private land or access roads to private land. As such, implementation of the recommendations will be largely dependent on the participation of landowners. The City of Boulder is committed to encouraging the participation of as many interested landowners as possible. There are also mitigation recommendations for individual structures which are the responsibility of the homeowner. Homeowners will, however, need a point of contact, most likely a member of the BFD, to help them implement these recommendations. The best defensible space will be created with oversight and expert advice from the fire district and or government forestry personnel. One-on-one dialog will continue to build the relationship with community members. This level of involvement will allow agencies to keep track of the progress and update this plan to reflect the latest modifications at the community level. The BFD web site is <http://www.bouldercolorado.gov>. This site has information for citizens, as well as a way to contact the district for more information or input regarding current and planned mitigation actions.

## **The Collaborative Process**

“The initial step in developing a CWPP should be the formation of an operating group with representation from local government, local fire authorities, and the state agency responsible for forest management ... Once convened; members of the core team should engage local representatives ... to begin sharing perspectives, priorities, and other information relevant to the planning process.”<sup>1</sup>”

Eight federal, State, local, and private agencies (stakeholders) participated in the City of Boulder CWPP. These stakeholders are:

- The City of Boulder
- The United States Forest Service
- The Colorado State Forest Service
- Anchor Point Group

The true collaborative process was initiated thru a number of stakeholder meetings held within Boulder County. The purpose of the meetings was to bring all past, current, and future efforts and needs to the table. The primary focus was on the identification and delineation of communities, areas of concern, and values at risk. Best practices and anticipated “roadblocks” were identified. Within the City of Boulder ten communities were delineated and analyzed for hazard and risk.

Three meetings were held, two BFD fire board meeting and a public meeting located at the BFD. The purpose of these meetings was to discuss the findings of the CWPP and to begin the process of prioritizing future actions based on the recommendations in the CWPP. Options for homeowners and land managers to reduce structural ignitability and protect values in their communities were presented in the public meeting as well as landscape scale and cross-boundary mitigation project recommendations.

## **Funding CWPP Recommendations**

There are many sources of funds available for implementing the recommendations within the CWPP. Some available grants and websites where more information can be found are provided below.

- Agency: Homeland Security, Office for Domestic Preparedness
  - Purpose: to assist local, state, regional, or national organizations in addressing fire prevention and safety. The emphasis for these grants is the prevention of fire-related injuries to children.
  - More information: <http://www.firegrantsupport.com/>
  
- Agency: Federal Emergency Management Agency (FEMA)
  - Purpose: to improve firefighting operations, purchase firefighting vehicles, equipment, and personal protective equipment, fund fire prevention programs, and establish wellness and fitness programs.
  - More information: <http://usfa.fema.gov/dhtml/inside-usfa/grants.cfm>
  
- Agency: National Volunteer Fire Council
  - Purpose: to support volunteer fire departments
  - More information: <http://www.nvfc.org/federalfunding.html>
  
- Agency: Community Facilities Grant Program
  - Purpose: to help rural communities. Funding is provided for fire stations
  - More information: [www.rurdev.usda.gov/rhs/](http://www.rurdev.usda.gov/rhs/)
  
- Agency: Firehouse.com
  - Purpose: emergency services grants
  - More information: [www.firehouse.com/funding/grants.html](http://www.firehouse.com/funding/grants.html)
  
- Agency: Cooperative Forestry Assistance
  - Purpose: to assist in the advancement of forest resources management, the control of insects and diseases affecting trees and forests, the improvement and maintenance of fish and wildlife habitat, and the planning and conduct of urban and community forestry programs
  - More information: [www.usfa.fema.gov/dhtml/inside-usfa/cfda10664.html](http://www.usfa.fema.gov/dhtml/inside-usfa/cfda10664.html)



- Agency: Forest Service, Economic Action Programs
  - Purpose: Economic Action Programs that work with local communities to identify, develop, and expand economic opportunities related to traditionally underutilized wood products and to expand the utilization of wood removed through hazardous fuel reduction treatments.
  - More information: [www.fireplan.gov/community\\_assist.cfm](http://www.fireplan.gov/community_assist.cfm)
  
- Agency: FEMA
  - Purpose: Assistance to Firefighters Grant Program
  - More information: [www.usfa.fema.gov/dhtml/inside-usfa/apply.cfm](http://www.usfa.fema.gov/dhtml/inside-usfa/apply.cfm) and [www.nvfc.org/federalfunding.html](http://www.nvfc.org/federalfunding.html)