

CURB CONTRACTION JOINT

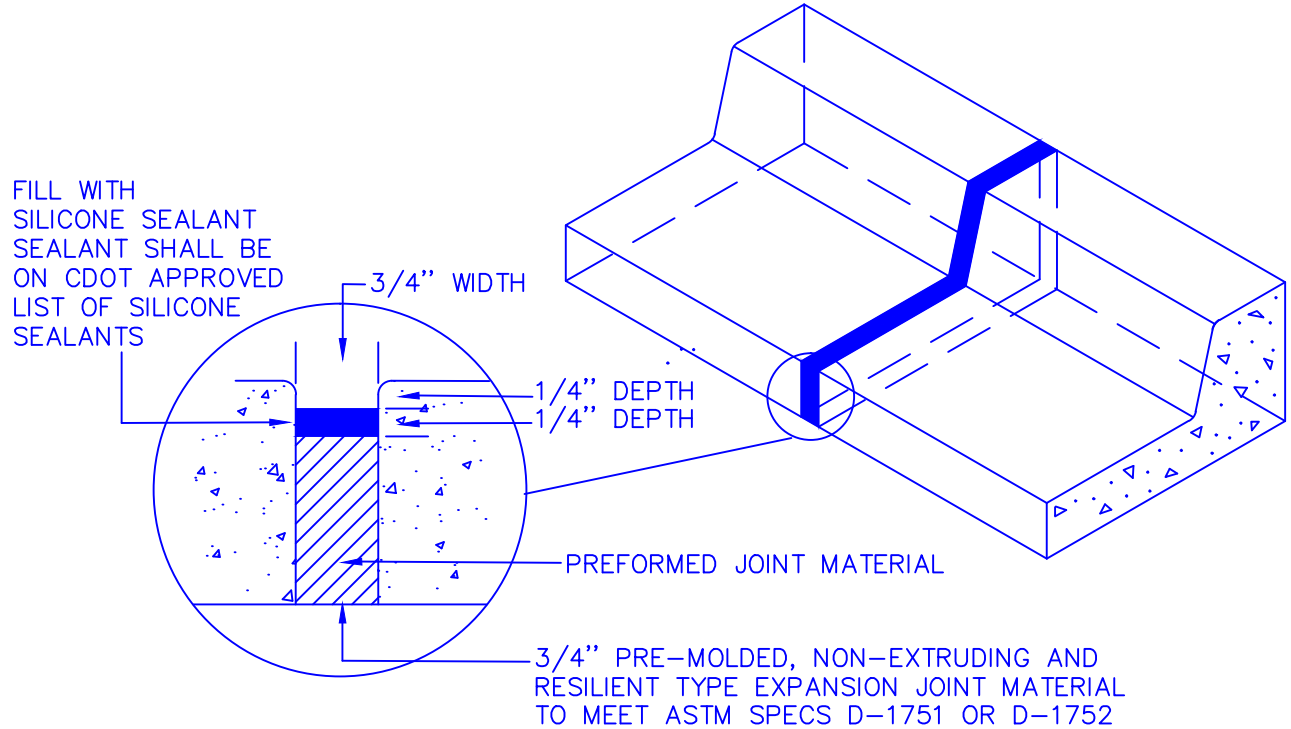

CURB EXPANSION JOINT

DRAWN BY: JSH  
 CHECKED BY: WGH

APPROVED BY:  
 DIRECTOR OF PUBLIC WORKS

CITY OF BOULDER, COLORADO  
**CURB AND GUTTER JOINTS**

ISSUED: JULY 2, 1998  
 REVISED: OCT 6, 2009

DRAWING NO.  
 2.01.B